

Parts Manual

Bulldog 26" ECO Floor Scrubber
Traction Drive Disc

Technical Specifications

Model *Bulldog 26" ECO Traction Drive Disc*

Model No. WD26



Current (Max)	40 amps
Battery Capacity (Lead Acid)	140Ah @20 hr
Battery Capacity (Sealed)	135Ah @20 hr
Sound Level	69 dBA
Cleaning path width	26 in (65 cm)
Squeegee width	38 in (95 cm)
Productivity	TBD ft ² /hr (TBD m ²)
Working Speed	TBD mph (TBD km per hr)
Transport Speed	TBD mph (TBD km per hr)
Rated voltage	24 volts
Vacuum flow	65 cfm (110 m ³ /hr)
Vacuum waterlift	45 inches (112mbar)
Vacuum power	.60 HP (450 W)
Brush type	Disc
Brush motor(s) power	3/4 HP (550W)
Number of brushes	2
Brush RPM	180 RPM
Solution capacity	12Gal (45 liters)
Recovery capacity	13 Gal (49 liters)
Working Grade	2%
Weight with batteries	370lbs (168 kg)
Weight without batteries	235 lbs (107 kg)
Dimensions (LxWxH)	48 x 26.0 x 38.0 (112.8 x 47.8 x 107.4 cm)
Drive Motor Power	1/5 HP (150W)

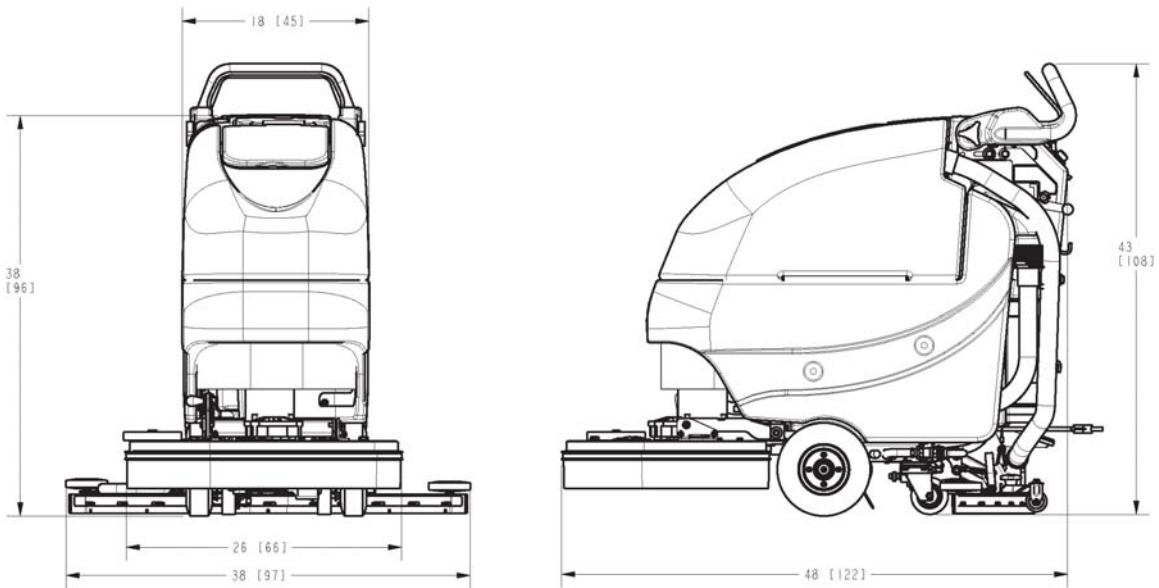

For Safety When Servicing or Maintaining Machine

- Stop on level surface.
- Disconnect the power to the machine by pulling the red Battery Connector located under the recovery tank near the batteries.
- Avoid moving parts. Do not wear loose jackets, shirts, or sleeves when working on machine.
- Avoid contact with battery acid. Battery acid can cause burns. When working on or around batteries, wear protective clothing and safety glasses. Remove metal jewelry. Do not lay tools or metal objects on top of batteries.
- Do not clean machine with a pressure washer.
- Authorized personnel must perform repairs and maintenance. Use Minuteman supplied replacement parts.



Table of Contents

Main Assembly	1
Main Assembly BOM	2
Base Assembly	3
Base Assembly BOM	4
Base Assembly	5
Chassis Assembly	6
Chassis Assembly BOM	7
Solution Tank Assembly	8
Recovery Tank Assembly	9
Recovery Tank Assembly BOM	10
Handle Assembly	11
Solution Valve Assembly	12
Battery Tray Assembly	13
Electrical Box Assembly	14
Electrical Box Assembly BOM	15
Electrical Box Cover Assembly	16
Vacuum Motor Assembly	17
Rear Squeegee Assembly - View 1	18
Rear Squeegee Assembly - View 2	19
Squeegee Mechanism Assembly	20
Optional Pump Kit	21
Wiring Diagrams	22

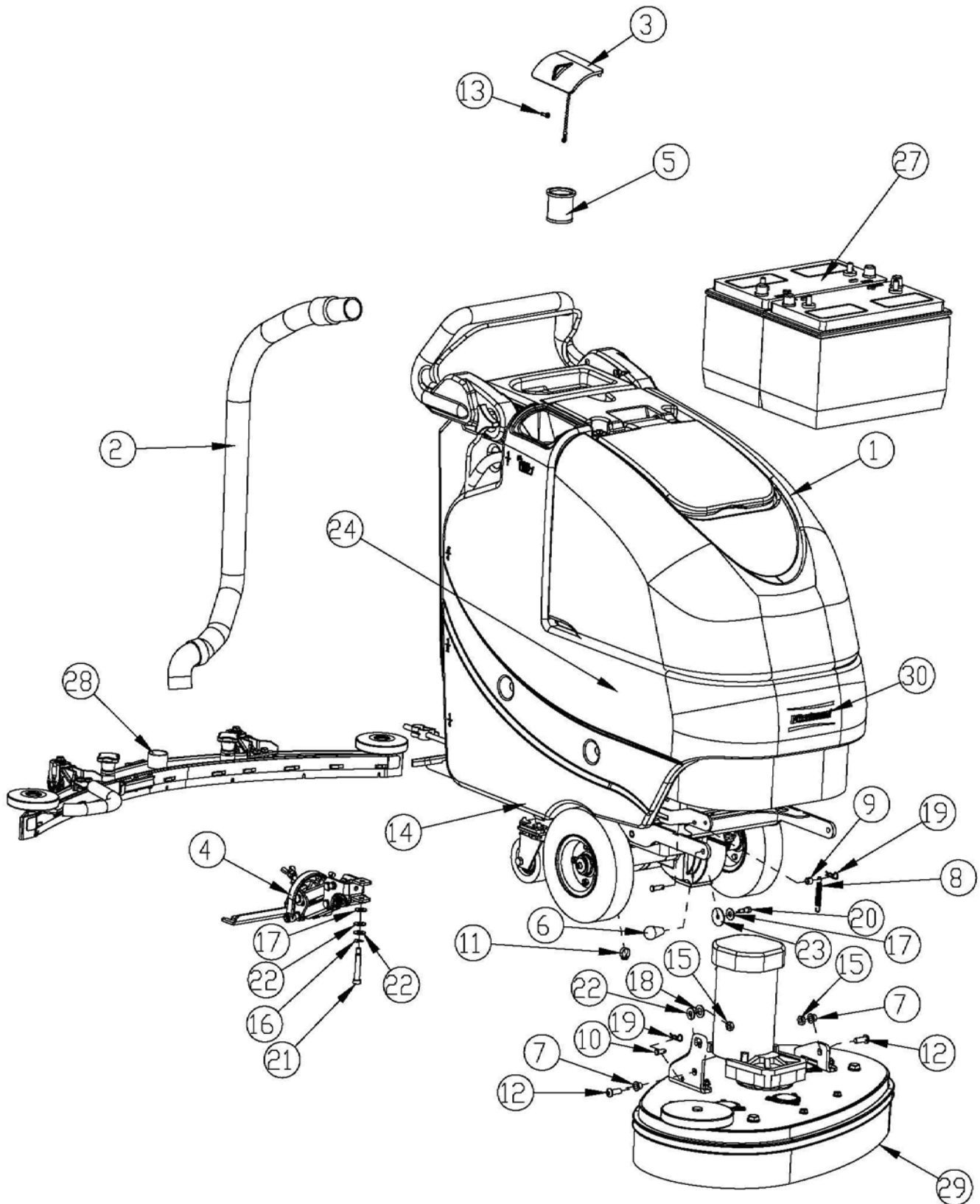



BILL OF MATERIAL			
ITEM	PART NO.	REQ'D	DESCRIPTION
1	172001-26FC	1	E26ECO BASE ASM
2	172010	1	HOSE, CLEAR VAC W/45 CUFF
3	172018	1	SOLUTION TANK LID ASSY
4	172150	1	SQUEEGEE LIFT MECH ASSY
5	172159	1	FILTER, FILL PORT
6	172423	1	KNOB, TAPERED 1/4-20
7	260066	2	OILITE BUSHING
8	281047	1	SPRING, EXTENSION - 2.75"
9	370058	1	BUSHING, .31 X .48X.385 SS
10	450034	1	CLEVIS PIN, 5/16 X .75 LG
11	450076	1	CLAMP-CRIMP 185R SS
12	710995	2	SCR-SC 3/8-24 X 1.0 BHEAD ST PL
13	711118	1	SCR-ST-A 10 X .75 SS
14	711523	1	WSR-WAVE .37X .68 X .08
15	711569	2	WSR-FLT .390 X .880 X .062 NYL
16	711592	1	WSR-FLAT .506 X .9 X .064 NYL
17	711808	2	COTTER PIN-HAIR #13
18	712041	1	BLT - SHLDR .31 X .375 X 1/4-20
19	712143	1	BLT-SHLD 3/8 X 2.0, 5/16-18
20	712301	2	WSR-FLAT .37 X .87 X .06
21	712759	1	WSR-FLT .31 X 1.37 X .06 SS
22	715921FC	2	DECAL, WD20
23	740164-1	1	JUMPER CABLE ASSY, RED 4G 12"
24	747649	1	CABLE ASSY, BATTERY E17
25	956135	2	BATTERY, 12V 135AH
26	3400067	2	NUT-HEX 3/8-24 ZP
27	97094502	1	950MM SQUEEGEE ASSEMBLY
28	99711100	1	26ECO DISC BRUSH DECK
29	715914FC	1	DECAL, BULLDOG
30	172008	1	SOLUTION TANK LID
31	172123	1	CHAIN, BEADED SS W/EYELETS
32	712145	1	SCR-MC 6-32 X .37 PPH SS

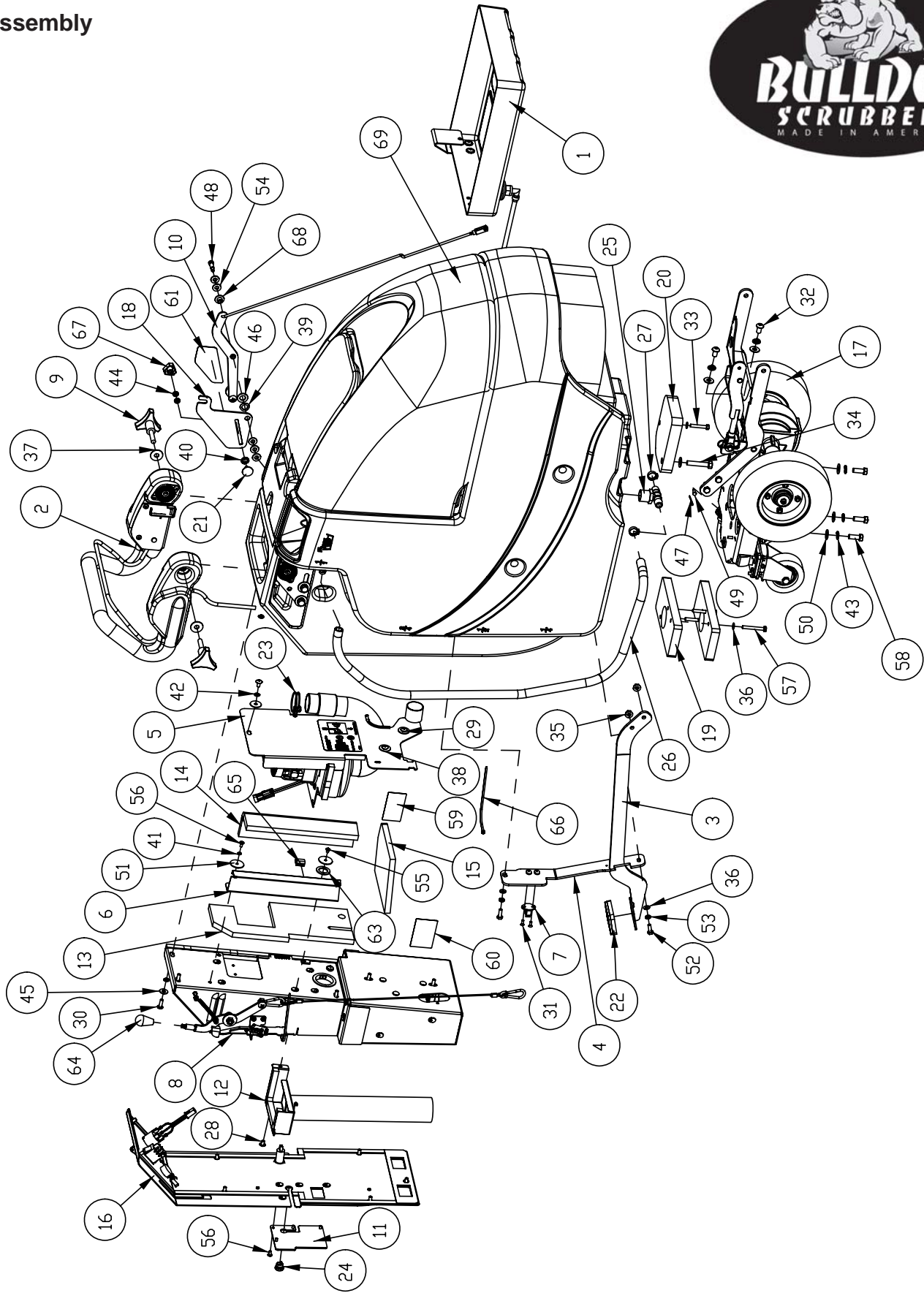

Base Assembly BOM



BILL OF MATERIAL - 172001-26FC

ITEM	PART NO.	REQ'D	DESCRIPTION	ITEM	PART NO.	REQ'D	DESCRIPTION
1	172012	1	BATTERY TRAY ASSY	35	711519	3	WSR- FLAT .25 X 1.01 X .06
2	172015-26	1	26ECO HANDLE ASM.	36	711524	1	WSR-WAVE .52 X .87 X .01
3	172032	1	LIFT PEDAL WMT	37	711539	1	WSR-EXTERNAL LOCK 3/8
4	172036	1	BKT , PEDAL STOP	38	711543	1	WSR-HELICAL #10
5	172050	1	VAC MOTOR ASSY	39	711544	9	WSR-HELICAL 1/4
6	172055	1	BKT , VAC AREA INSIDE COVER	40	711546	6	WSR-HELICAL 3/8
7	172065	1	CLIP, FOR 1/2" ID HOSE	41	711566	2	WSR-FLAT .259 X .500 X .065
8	172075-120	1	ELEC BOX TD ASSY 120V	42	711575	5	WSR-FLT .31x.75x.06ST
9	172085	2	KNOB, 3/8-16 STUD, 3 LOBE	43	711592	1	WSR-FLAT .506 X .9 X .064 NYL
10	172112	1	SOL CONTROL ASSY	44	711803	1	COTTER PIN
11	172129	1	BKT , PWR CORD MOUNT	45	712070	1	BLT-SHOULDER 5/16 X 3/4 X 1/4-
12	172179	1	CHARGER INLET ASSEMBLY	46	712117	1	CLEVIS PIN 3/16
13	172184	1	FOAM COVER, REAR 1	47	712301	6	WSR-FLAT .37 X .87 X .06
14	172185	1	FOAM COVER, REAR 2	48	712312	2	WSR-FLAT .187 X 1.25
15	172187	1	FOAM COVER, FRONT 2	49	712562	2	BOLT -HH 1/4-20X3/4 SS
16	172330-26	1	DASH PANEL ASSY-26ECO	50	712758	2	WSR-HELICAL 1/4 SS
17	172409	1	CHASSIS ASM, 26ECO	51	712772	5	WSR-FLAT .344 x .75 x .06 SS
18	172416	1	BKT , AQUASAVER SOL CTRL	52	712800	1	SCR-MC 10-24 X .25 ST PL
19	172421	2	WEIGHT, 26ECO	53	712810	5	SCR-MC 10-24 X .37 ST PL
20	172424	1	BLT-ELEVATOR, 1/4-20 X .75 ZINC	54	713007	3	BLT-HH 1/4-20 X 2 #5
21	210142	1	PEDAL PAD	55	713042	4	BLT-HH 3/8-16 X 1 #5
22	260203	1	WIRE GRIP HOSE CLAMP	56	715029	1	DECAL-NAME PLATE SERIAL
23	293080	1	STRAIN RELIEF-HEYCO 1207	57	715047	1	DECAL-CLEAR LAMINATE 2X3
24	342440	1	FITTING, TEE 3/4MPT 1/2BARB	58	715690	1	DECAL, AQUASAVER SOL CTRL
25	430156	1	HOSE, 1/2 X 42 CLEAR	59	715950	1	LABEL, PAT ENT NUMBERS
26	450093	2	CRIMP CLAMP 3/4" STEPLESS	60	717025	1	WSR-FLAT 13/16ID X 1.25 X .08
27	710177	1	SCR-MC 1/4-20 X .37 ST PL	61	760592	1	KNOB, OVAL TAPERED
28	710178	10	SCR-MC 1/4-20 X .50 TRUSS STPL	62	809443	1	CLIP-WIRE & CORD
29	710380	5	SCR-MC RD HD 1/4-20 X .75 STL PL	63	828062	1	CABLE TIE LARGE
30	710530	2	SCR-MC FL HD 8-32 X .50 BRS	64	833214	1	KNOB-3 SIDED 1/4-20
31	710985	2	SCR-SC 3/8-16 X .62 ST PL	65	840202	1	BUSHING-FLG .31 X .437 X .325 NYL
32	711379	2	NUT, FLANGED WIZZ 5/16-18	66	96118674	2	WEIGHT, PAINTED
33	711504	5	WSR-FLAT 1/4 ID SS	67	172001FC	1	BASE ASSY
34	711507	3	WSR-FLAT .37 X 1.12 X .06				

Base Assembly

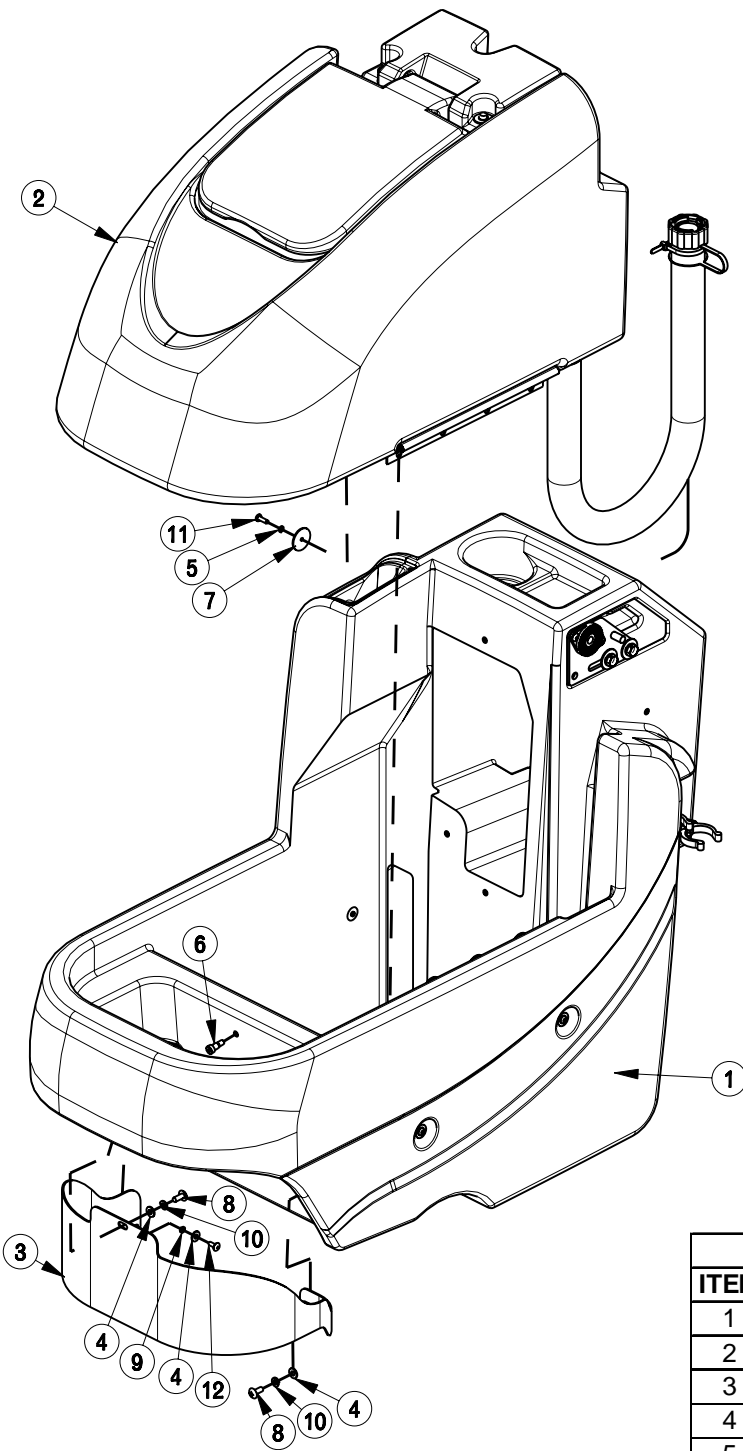

BILL OF MATERIAL - 172001FC			
ITEM	PART NO.	REQ'D	DESCRIPTION
1	172013FC	1	SOL TANK ASSY
2	172014FC	1	REC TANK ASSY
3	172144FC	1	PANEL, FRONT
4	711504	3	WSR-FLAT 1/4 ID SS
5	711543	4	WSR-HELICAL #10
6	712041	1	BLT- SHLDR 1/4-20 X .44 X .37
7	712312	4	WSR-FLAT .187 X 1.25
8	712565	2	SCR-MC 1/4-20X.63 SS TR HD
9	712757	1	WSR - HELICAL #10 SS
10	712758	2	WSR-HELICAL 1/4 SS
11	712812	4	SCR-MC 10-24 X .62 PPH ST PL
12	712822	1	SCR-MC TR HD 10-24 X .50 SS
13	172407	1	PLUG, FRONT PANEL (NOT SHOWN)
14	172408	1	PLUG, FRONT PANEL (NOT SHOWN)

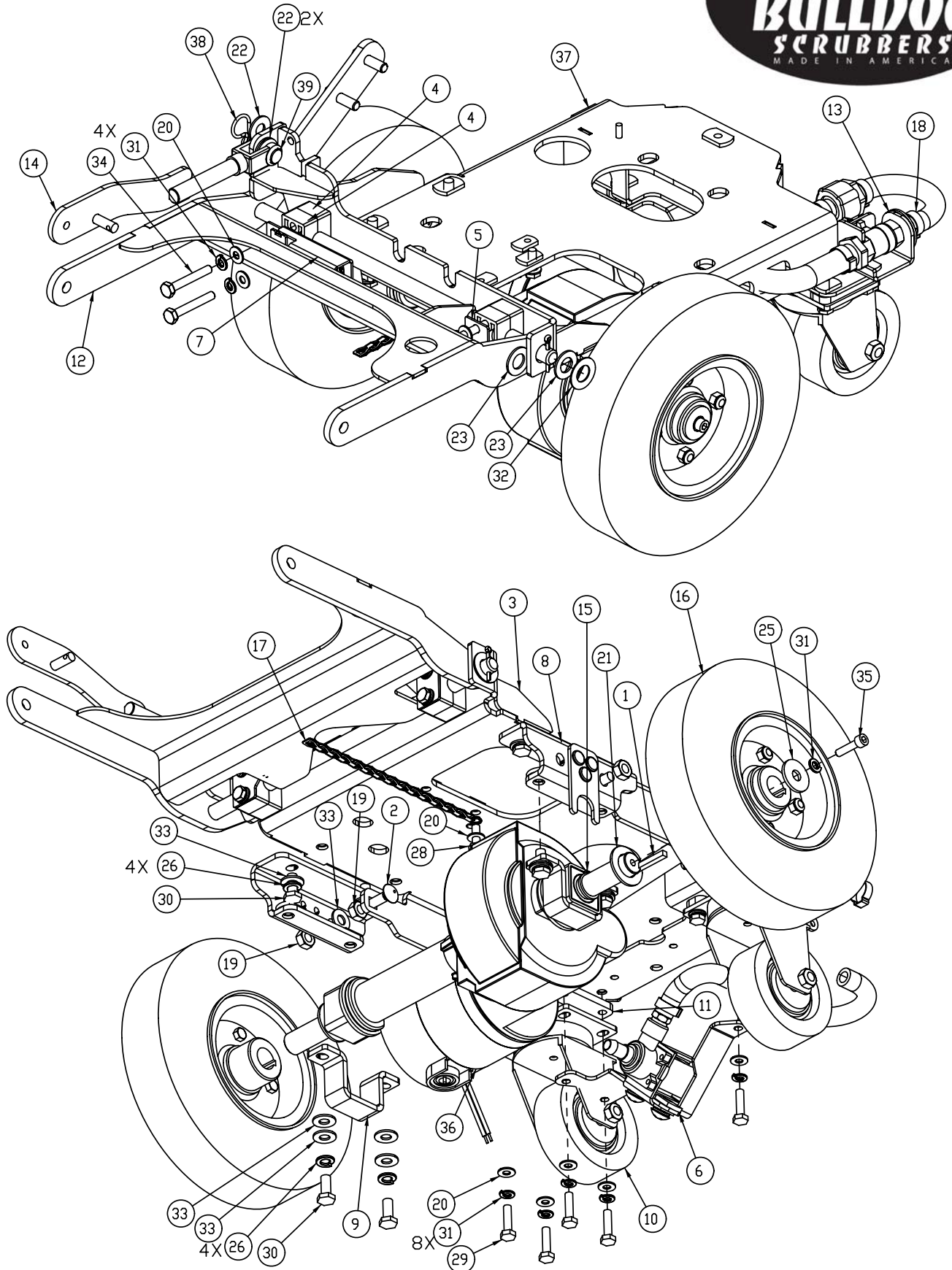

Chassis Assembly BOM



BILL OF MATERIAL - 172409			
ITEM	PART NO.	REQ'D	DESCRIPTION
1	61-65-A	2	KEY, 3/16 X 1-3/4"
2	70-516-16	2	BLT-CAR 5/16-18 X 1.00 ZP
3	172020	1	MAIN FRAME WMT, E1720
4	172038	4	BEARING BLOCK
5	172039	1	BEARING BLOCK PLATE
6	172104	1	TD SOLENOID ASSY
7	172110	1	DECK SWITCH ASSY
8	172113	2	BKT, TRANSAXLE MOUNT BASE
9	172114	2	BKT, TRANSAXLE MOUNT
10	172167	2	CASTER, 3-1/2 POLYURETHANE
11	172192	2	PLATE, 1/4" SPACER
12	172205	1	DECK LIFT WMT
13	172264	1	SOLUTION VALVE ASSY
14	172412	1	UPPER LIFT ARM WMT, E26ECO
15	172425	2	RING-RET EXT .75 HD
16	200172-2	2	WHEEL, 8.5" FOAM FILL
17	281200	1	DRAG CHAIN ASSY, FRAME
18	450076	1	CLAMP-CRIMP 185R SS
19	711383	4	NUT-HEX CLR LOC 5/16-18
20	711504	13	WSR-FLAT 1/4 ID SS
21	711512	2	WSR-FLAT .75X1.37X.08
22	711569	3	WSR-FLT .390 X .880 X .062 NYL
23	711592	2	WSR-FLAT .506 X .9 X .064 NYL
24	711809	1	COTTER PIN, 1/8 X 1.0
25	711855	2	WSR-FLT .37X1.12X.10 STL Z HARD
26	712140	8	WSR-HELICAL 5/16 SS
27	712265	1	CLEVIS-YOKE, 1/2-20 W/ .375 PIN
28	712562	1	BOLT-HH 1/4-20X3/4 SS
29	712564	8	BOLT-HH 1/4-20X1.00 SS
30	712575	8	BLT-HH 5/16-18 X .75 SS
31	712758	14	WSR-HELICAL 1/4 SS
32	712760	1	WSR-FLAT .56X1.06X.04 SS
33	712772	14	WSR-FLAT .344 x .75 x .06 SS
34	713006	4	BLT-HH 1/4-20 X 1 3/4 #5
35	717026	2	SCR-SC SHCS M6X1.0 X 25 STL Z
36	747606	1	TRANSAXLE, ES1720 24V
37	809444	1	CLIP-CORD
38	833374	1	PIN, HAIRPIN COTTER 3/8
39	833833	1	PIN-CLEVIS 3/8 X 1.25

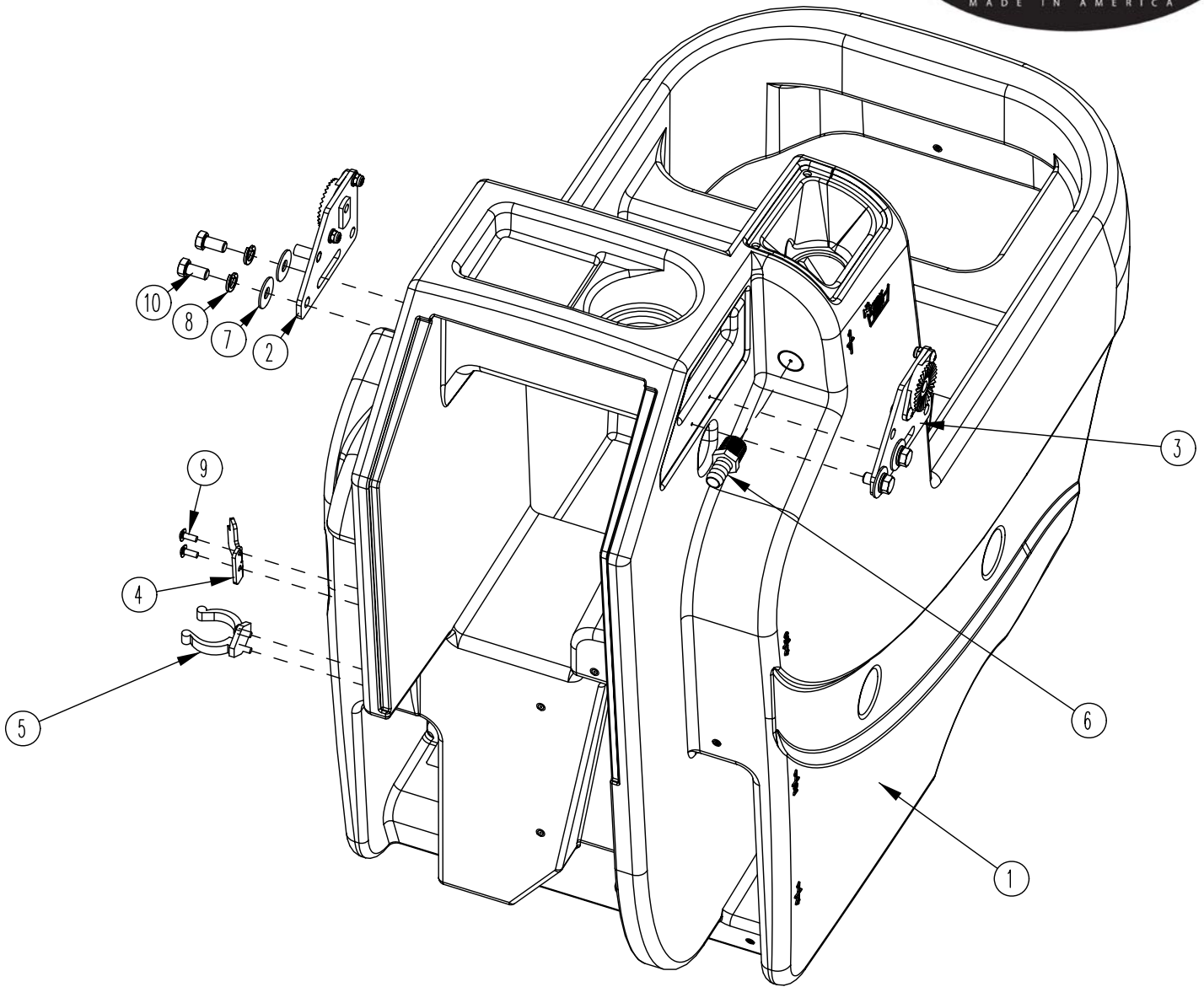

BILL OF MATERIAL - 172013FC			
ITEM	PART NO.	REQ'D	DESCRIPTION
1	172003FC	1	SOLUTION TANK
2	172080	1	HANDLE MOUNT ASSY, LEFT
3	172082	1	HANDLE MOUNT ASSY, RIGHT
4	172341	1	HOOK, DRAIN HOSE WITH TWIST VALVE
5	260579	1	TOOL CLIP, 1.5" HOSE
6	342438	1	FITTING, 1/2 MPT 1/2 HB BRASS
7	711507	4	WSR-FLAT .37 X 1.12 X .06
8	711546	4	WSR-HELICAL 3/8
9	712822	4	SCR-MC TR HD 10-24 X .50 SS
10	713041	4	BLT-HH 3/8-16 X 3/4 #5

Recovery Tank Assembly

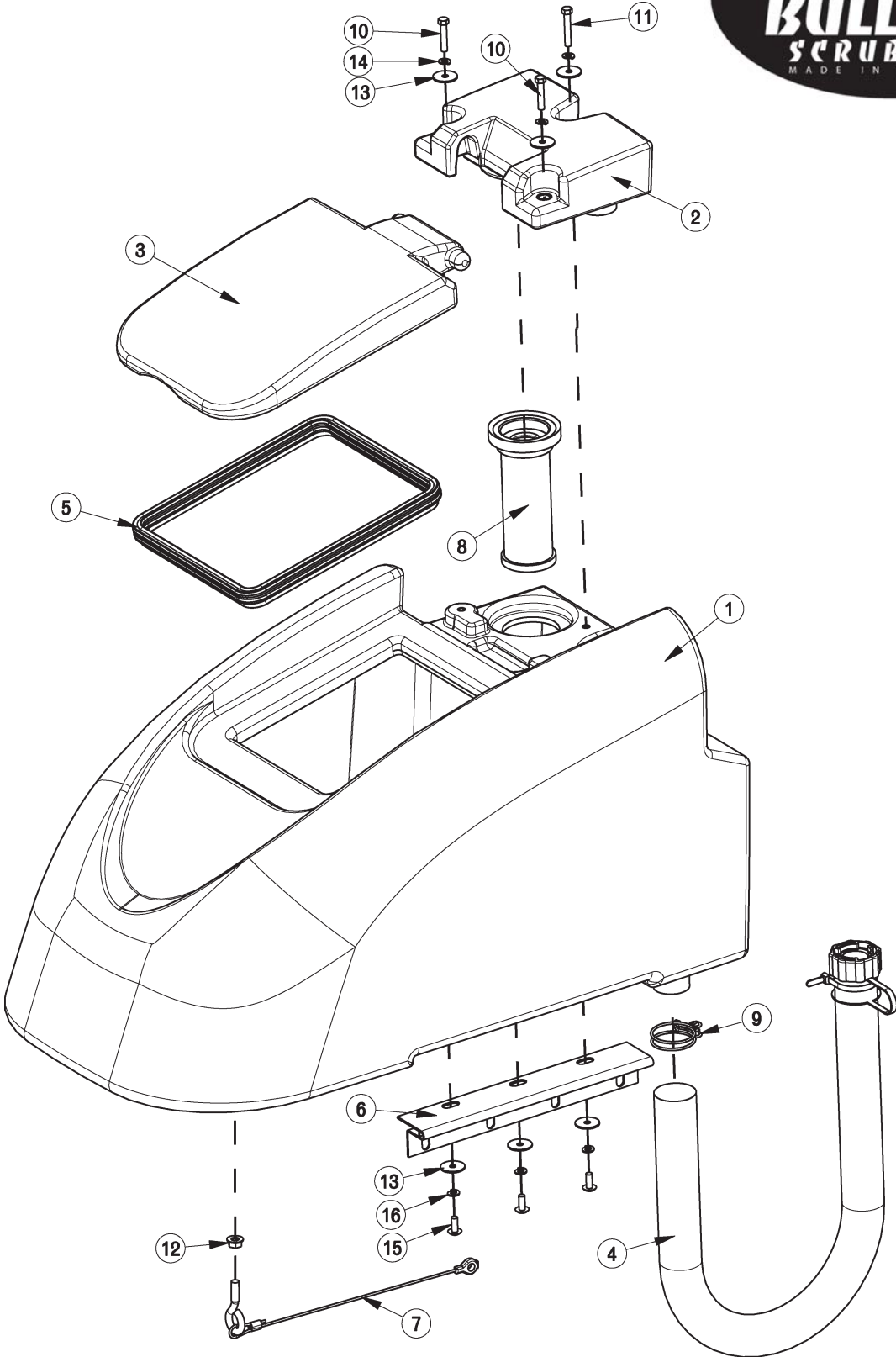



BILL OF MATERIAL - 172014FC			
ITEM	PART NO.	REQ'D	DESCRIPTION
1	172004FC	1	RECOVERY TANK
2	172005FC	1	VACUUM MANIFOLD
3	172007FC	1	LID
4	97090096	1	DRAIN HOSE ASSY, RECOVERY TANK
5	172017	1	GASKET, LID
6	172049	1	HINGE, RECOVERY TANK
7	172394	1	REC TANK CABLE ASSY 11.625
8	172132	1	SCREENED FLOAT
9	172329	1	CLAMP-HOSE 1.56" 102122 MURRAY
10	711210	2	BLT-HH 1/4-20 X 1.25 STPL
11	711212	1	BLT-HH 1/4-20 X 1.50 STPL
12	711379	1	NUT, FLANGED WIZZ 5/16-18
13	711519	6	WSR- FLAT .25 X 1.01 X .06
14	711544	3	WSR-HELICAL 1/4
15	712565	3	SCR-MC 1/4-20X.63 SS TR HD
16	712758	3	WSR-HELICAL 1/4 SS
17	15282072	1	REPLACEMENT O-RING (NOT SHOWN)
18	90304528	1	REPLACEMENT CAP

Handle Assembly

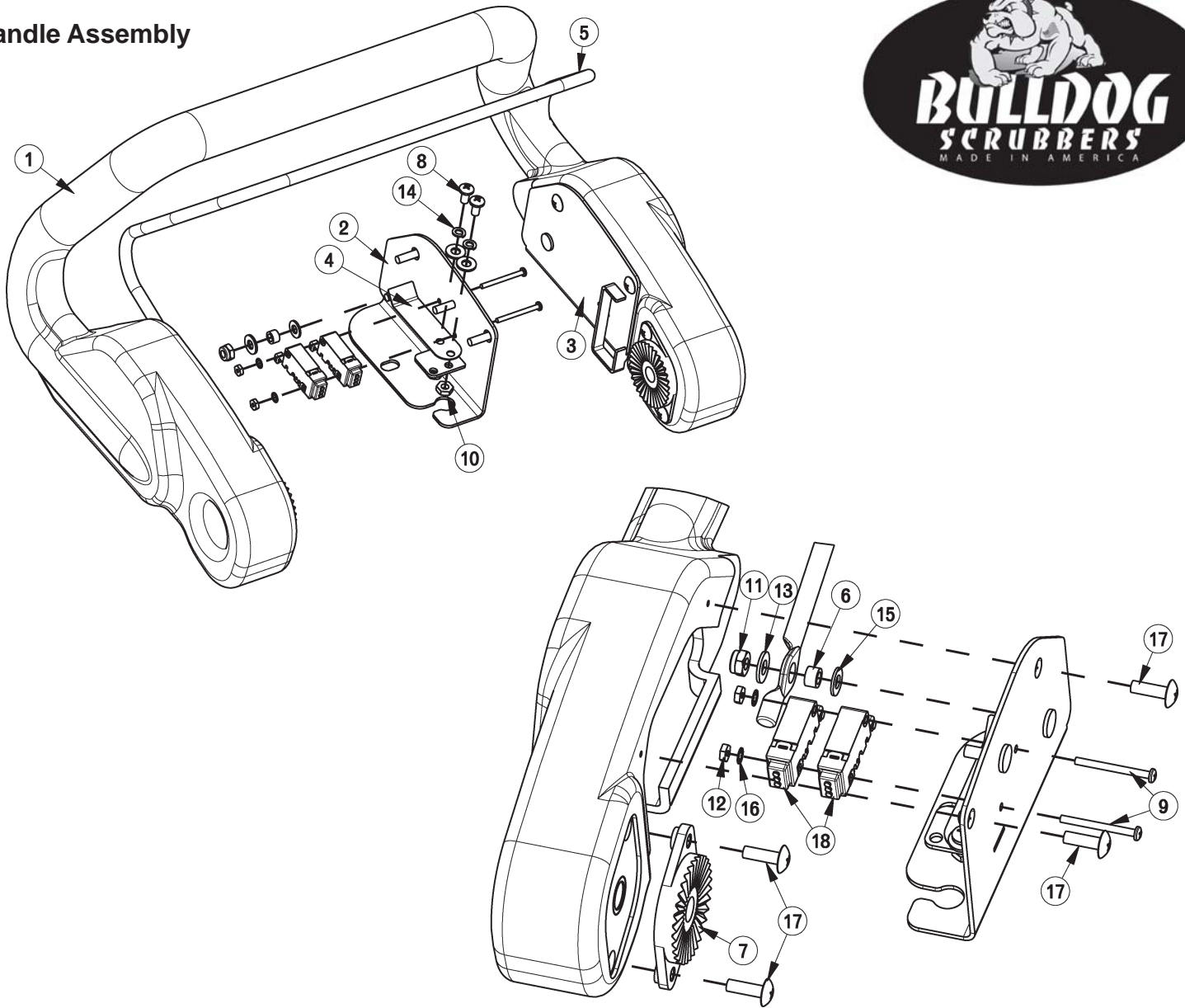

BILL OF MATERIAL - 172015

ITEM	PART NO.	REQ'D	DESCRIPTION	ITEM	PART NO.	REQ'D	DESCRIPTION
1	172006	1	HANDLE	11	711350	2	NUT-NYLOC 10-32
2	172053	1	BAIL PLATE WMT RH	12	711428	2	NUT-HEX 4-40
3	172054	1	BAIL PLATE WMT LH	13	711503	6	WSR, FLAT #10
4	172057	2	LEAF SPRING	14	711543	4	WSR-HELICAL #10
5	172059	1	BAIL, HANDLE	15	712320	2	WSR-NYLON .22 X .45 X .04
6	172074	2	SPACER, 5/16OD X 17GA, ALUM	16	712326	2	WSR-INT LOCK #4
7	270143	2	HANDLE PIVOT JAW	17	712830	10	SCR-MC 10-24 X .62 STLZ TR HD
8	710353	4	SCR-MC RD HD 10-32 X .37 STL	18	747603-1	2	SWITCH ASY, MICRO ROLLER W/PACK/CONDUIT
9	710495	2	SCR-MC 4-40 X 1.25 STLZ	19	747632-1	1	CABLE ASY, 5 COND 18G TD
10	711310	4	NUT, HEX 10-32 ST PL				

Solution Valve Assembly

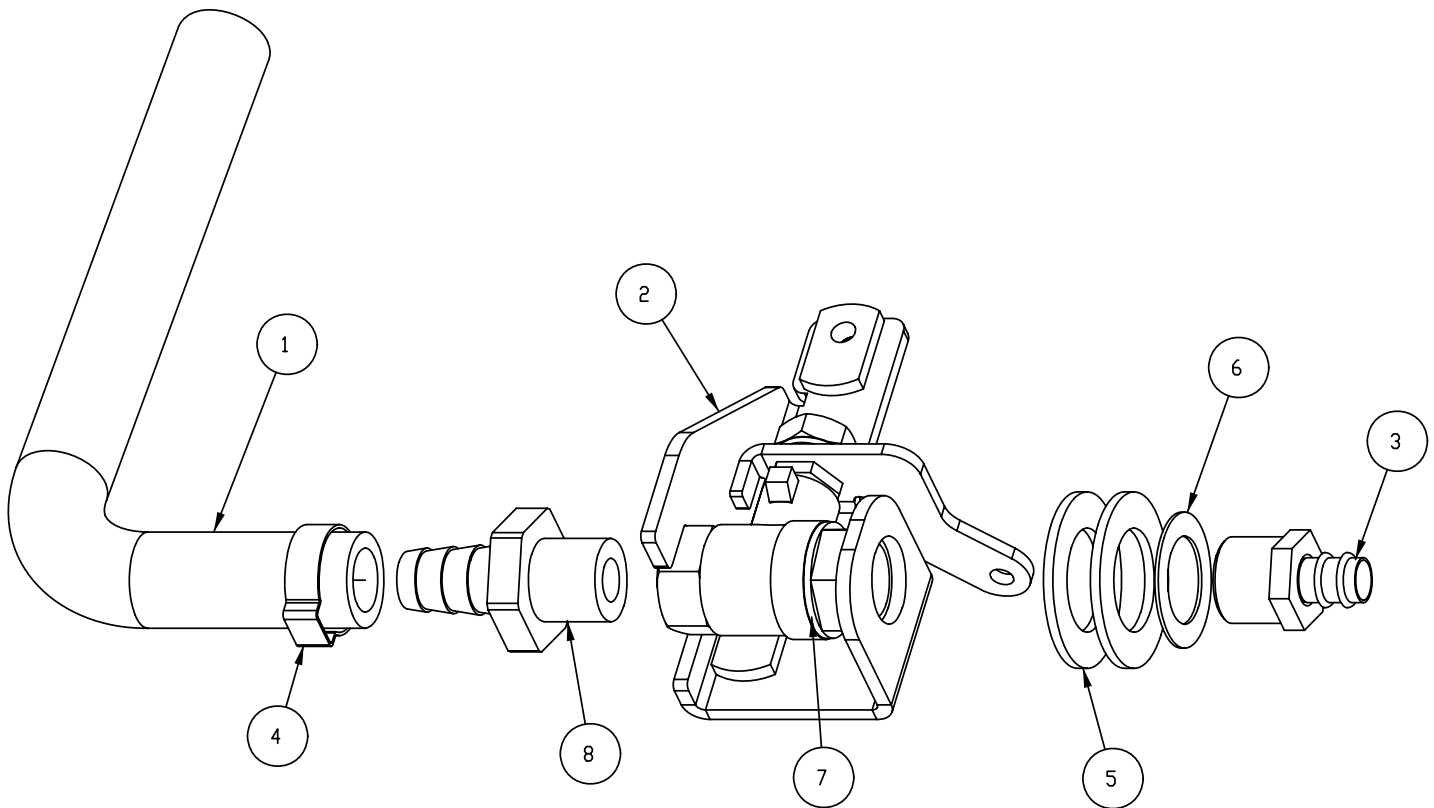

BILL OF MATERIAL - 172264			
ITEM	PART NO.	REQ'D	DESCRIPTION
1	172158	1	HOSE, 1/2"ID X 7.5" NYLOBRAID
2	172263	1	BKT, SOL VALVE MOUNT
3	320265	1	FITTING DUBL 3/8HBx3/8MPT
4	383347	1	CRIMP CLAMP 1/2 HOSE SS 185R
5	711512	2	WSR-FLAT .75X1.37X.08
6	711513	1	WSR-FLAT .69 X 1.06 X .03 SS
7	809415	1	VALVE, 3/8 FPT, 45 OPEN/CLOSE
8	827008	1	FITTING, 3/8 MPT 1/2 HOSE

Battery Tray Assembly

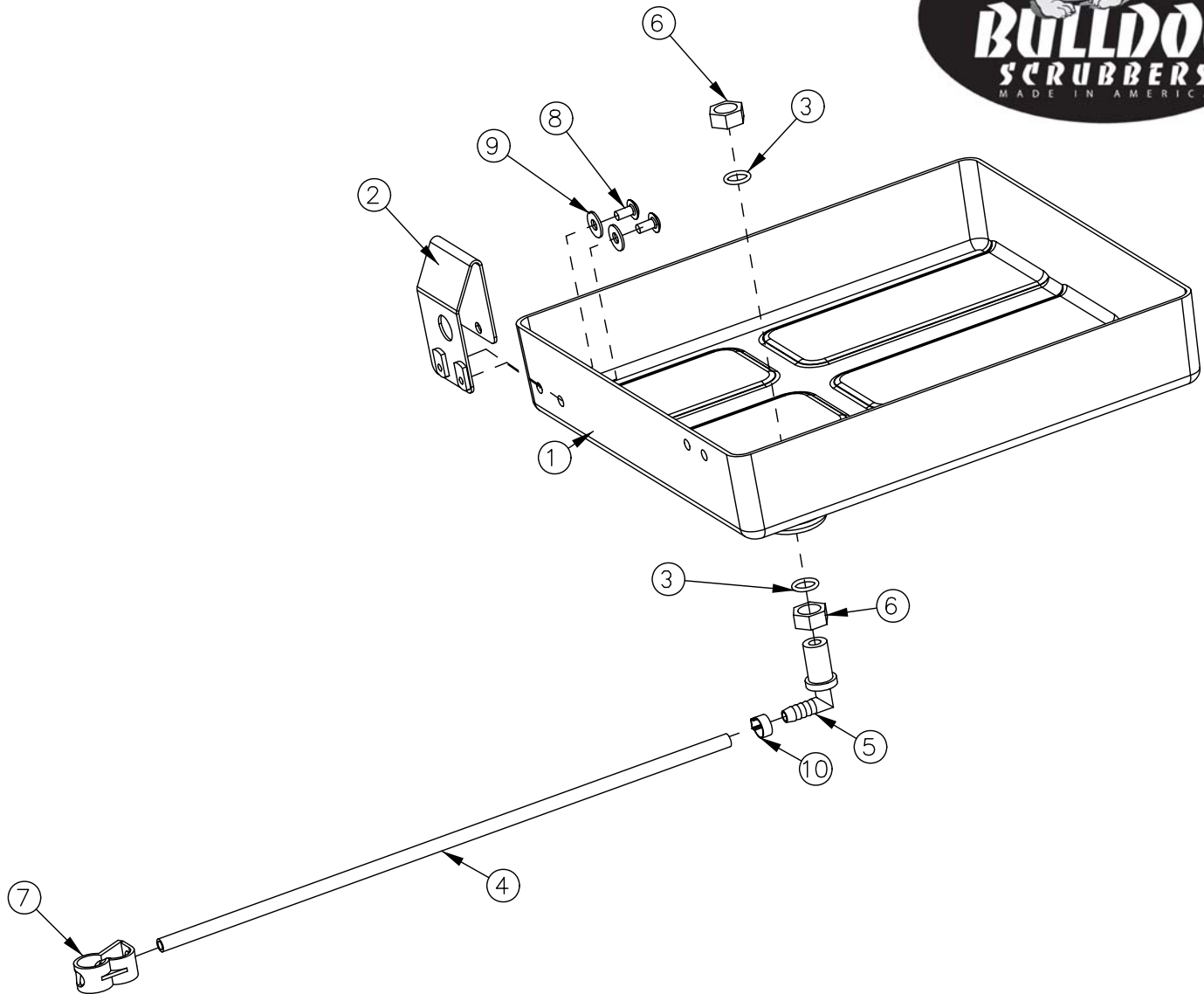

BILL OF MATERIAL - 172012			
ITEM	PART NO.	REQ'D	DESCRIPTION
1	172116	1	BATTERY BOX
2	172213	1	BKT, SPACER FOR BATTERIES
3	210414	2	O RING 2-113
4	260224	1	18" HOSE
5	320271	1	NOZZLE BODY-ELBOW
6	320272	2	NOZZLE BODY LOCKNUT
7	320273	1	HOSE SHUT-OFF CLAMP
8	710178	2	SCR-MC 1/4-20 X .50 TRUSS STPL
9	711575	2	WSR-FLT .31x.75x.06ST
10	828490	1	CRIMP CLAMP 140R

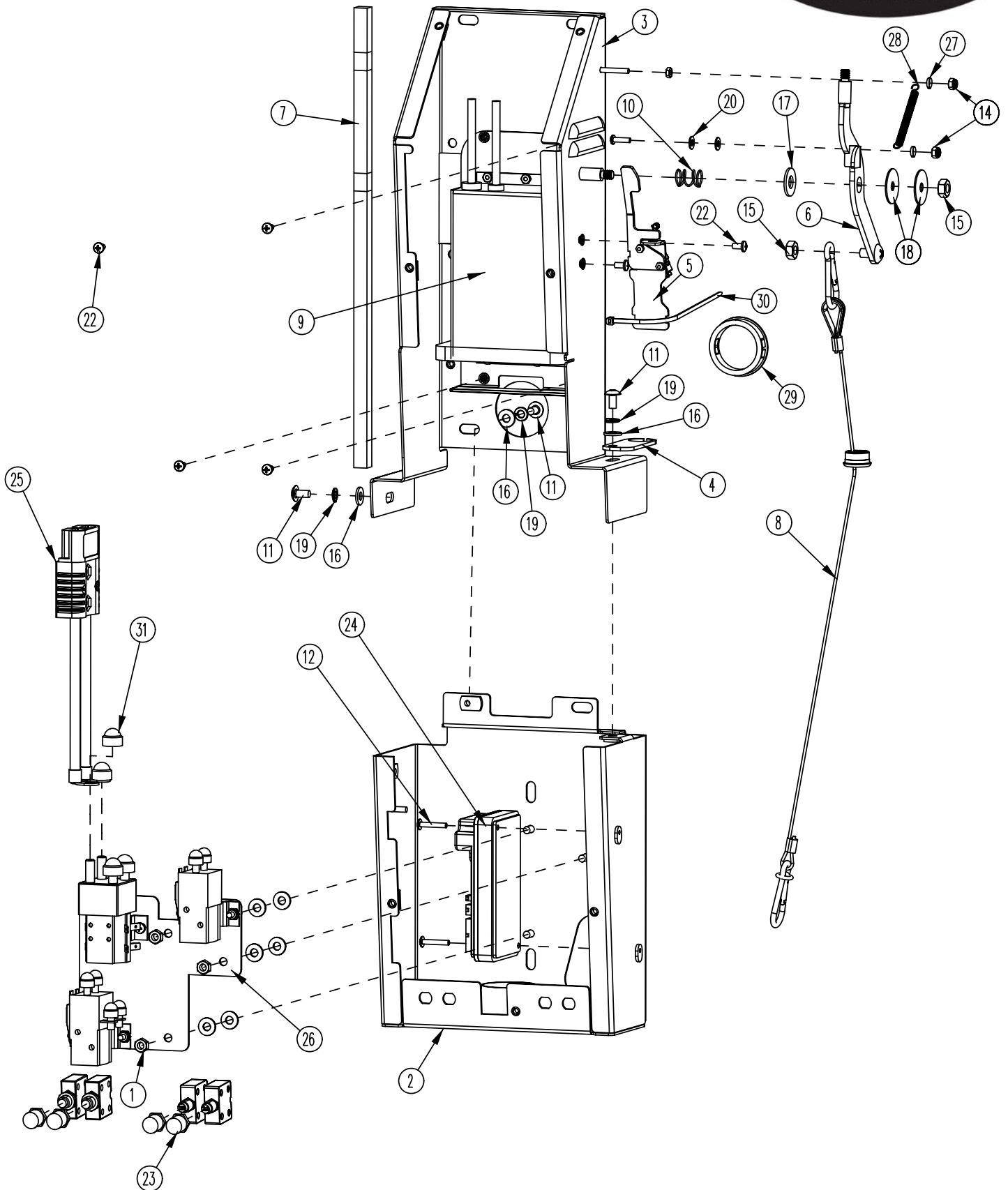



BILL OF MATERIAL - 172075-26			
ITEM	PART NO.	REQ'D	DESCRIPTION
1	369-416	3	NUT-HEX 1/4-20 NYLOC SERATED
2	172077	1	ELEC BOX-BOT HALF WMT
3	172088	1	ELEC BOX-TOP HALF WMT
4	172107	1	BKT, UPPER BUSHING MOUNT
5	172141	1	VAC SWITCH ASSY
6	172152	1	VAC LEVER WMT
7	172188_	1	FOAM TAPE, 1/2" SQ X 16.5"
8	172381	1	CABLE ASSY, SQUEEGEE LIFT
9	172385	1	120V CHARGER ASSEMBLY
10	670093	1	SPRING, COMPRESSION
11	710178	3	SCR-MC 1/4-20 X .50 TRUSS STPL
12	710534	2	SCR-MC TR HD 8-32 X 1.00 SS
13	711305	1	NUT, HEX 8-32 BR
14	711372	2	NUT-NYLOC 8-32 STL ZINC
15	711383	2	NUT-HEX CLR LOC 5/16-18
16	711505	9	1/4 FLAT WASHER, STEEL
17	711508	1	WSR-FLAT .44X 1.0X.08
18	711516	2	WSR- FLAT .31 X 1.25 X .05
19	711544	3	WSR-HELICAL 1/4
20	712320	2	WSR-NYLON .22 X .45 X .04
21	712770	6	WSR INT LOCK #10A SS
22	712810	6	SCR-MC 10-24 X .37 ST PL
23	742748	4	CIRCUIT BREAKER BOOT
24	747710	1	I-DRIVE, 24V 70A PM MOTOR CONTROL
25	747637	1	WIRE ASY, MACHINE-BATTERY
26	747670-26	1	ELEC PANEL ASSY
27	760134	2	MOUNT RING
28	762084	1	SPRING-EXT .25OD X 2" F.L. MUSIC
29	762400	1	HEYCO BUSHING 2.00"
30	828062	1	CABLE TIE LARGE
31	15592033_CAP	2	CAP, SAFETY NUT COVER M8

Electrical Box Cover Assembly

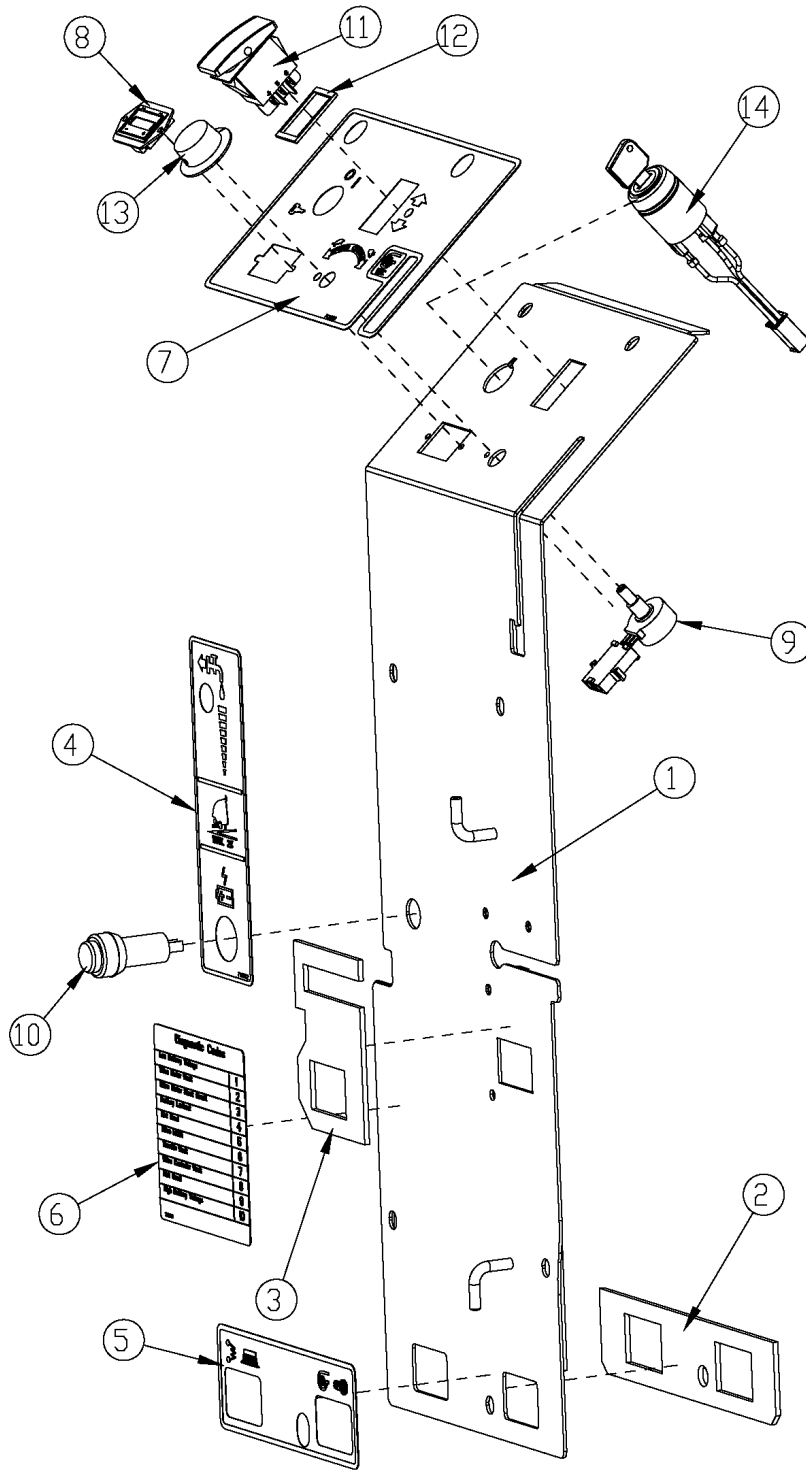

BILL OF MATERIAL - 172330-26FC

ITEM	PART NO.	REQ'D	DESCRIPTION	ITEM	PART NO.	REQ'D	DESCRIPTION
1	172182	1	TD COVER WMT	8	747011	1	BATTERY GAUGE, TRUCHARGE
2	172193	1	GASKET, CB OUTLINE	9	747026	1	POTENTIOMETER ASSY SPEED CONTROL
3	172194	1	GASKET, CHARGER CORD PLATE	10	747614	1	CHARGE STATUS INDICATOR
4	715672	1	DECAL, CHARGE STATUS, SOLUTION CTRL	11	748201	1	SWITCH, DPDT ON/OFF/ON
5	715674	1	DECAL, TD CIRCUIT BREAKER	12	748209	1	GASKET-FOR 2 POLE ROCKER SWITCHES
6	715678	1	DECAL. DIAGNOSTIC CODES	13	809874	1	KNOB, SPEED CONTROL
7	715680FC	1	DECAL, CYL DASHBOARD	14	90323437-1	1	KEYSWITCH ASY, SWITCH PLUS WIRES

Vacuum Motor Assembly

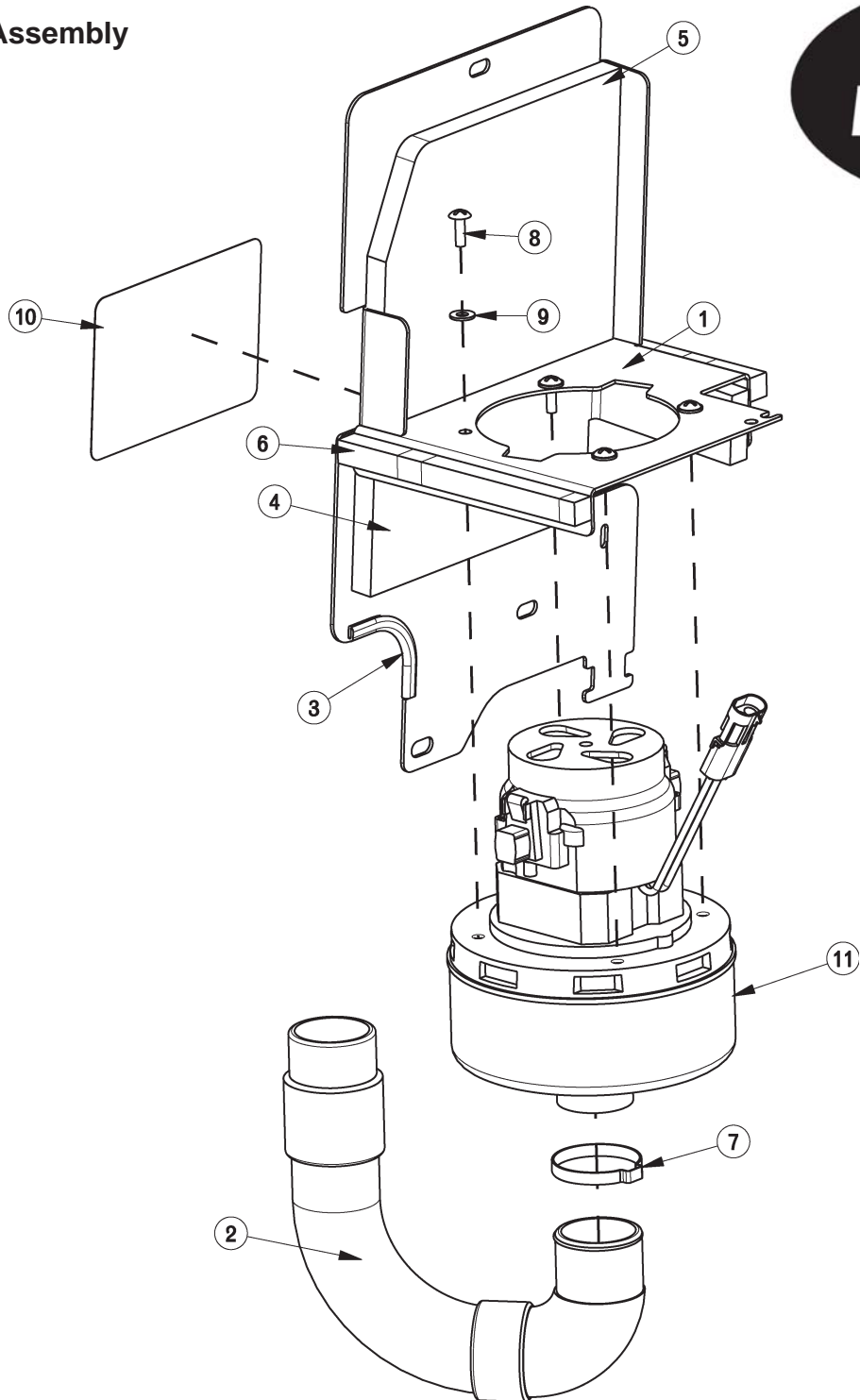

BILL OF MATERIAL - 172050

ITEM	PART NO.	REQ'D	DESCRIPTION	ITEM	PART NO.	REQ'D	DESCRIPTION
1	172045	1	VAC MOUNT WMT	7	450095	1	CRIMP CLAMP, 1.75"
2	172048	1	HOSE, STRETCH 13"	8	711160	4	#10 X 5/8 HI-LO
3	172124	1	EDGE TRIM, .063 X 3.0, BLACK	9	711503	4	WSR, FLAT#10
4	172186	1	FOAM COVER, FRONT 1	10	715676	1	DECAL, BATT CABLE ROUTE
5	172187	1	FOAM COVER, FRONT 2	11	747607-1	1	VAC MOTOR ASY
6	172188	2	FOAM TAPE, 1/2" SQ X 16.5"				

Rear Squeegee Assembly - View 1



BILL OF MATERIAL - 97094502 VIEW 1				
ITEM	PART NO.	REQ'D	DESCRIPTION	NOTES
1	96125844	1	Rear Retainer Strap L/H	
2	90494139	1	Rear Squeegee Blade	
3	96113279	1	Squeegee Tool	
4	90493560	1	Front Squeegee Blade	
5	96125836	1	Front Retainer Strap L/H	
6	90514506	2	Bushing	Part of ITEM 15
7	11518313	1	Eye bolt	Part of ITEM 15
8	12040283	2	Hex. Nut	Part of ITEM 15
9	90535758	1	Lever	Part of ITEM 15
10	11039765	2	Hexagon Screw	Part of ITEM 15
11	12022430	1	Hex. Nut	Part of ITEM 15
12	90513631	1	Pressure piece	Part of ITEM 15
13	96113303	1	Front Retainer Strap R/H	
14	96113428	1	Rear Retainer Strap R/H	
15	97057459	1	Latch Assembly	
16	17383209	1	Lock	

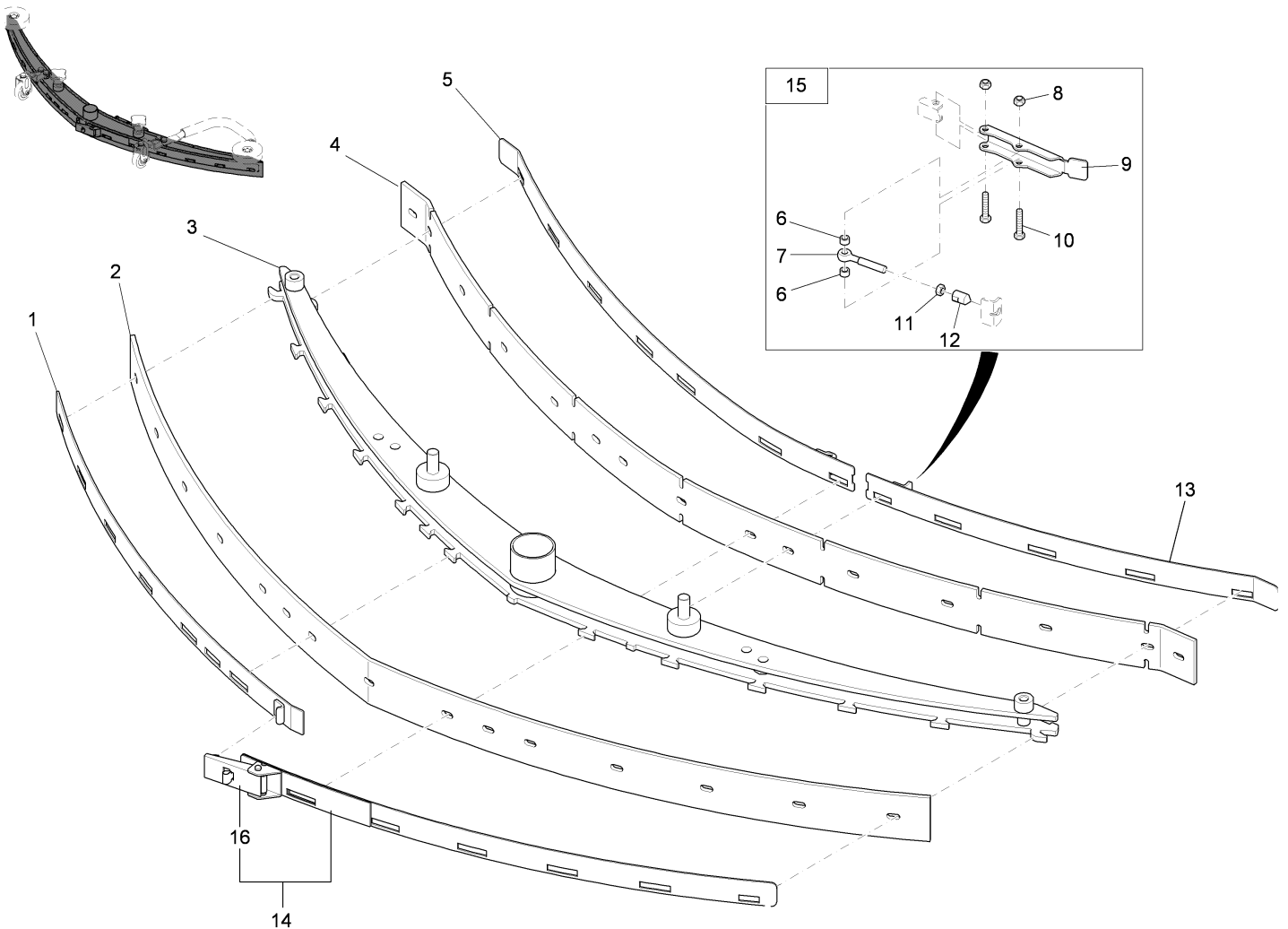

Rear Squeegee Assembly - View 2



BILL OF MATERIAL - 97094502 VIEW 2				
ITEM	PART NO.	REQ'D	DESCRIPTION	NOTES
1	11039567	6	Hexagon Screw	
2	12332136	2	Washer	
3	90199019	2	Pipe	
4	90548397	2	Deflector Roller	
5	11039609	2	Hex. Bolt	
6	12310264	4	Washer	
7	90513094	2	Fixed Caster Wheel	
8	97098842	2	Fixed Caster Wheel	
9	1077610	2	Distance Piece	
10	90514936	1	Distance Piece	
11	90515479	250mm	Hose	
12	90548413	1	Bracket	
13	12515094	2	Disk Wheel	
14	17133026	2	Star Handle	
15	90531112	10	Spacer	

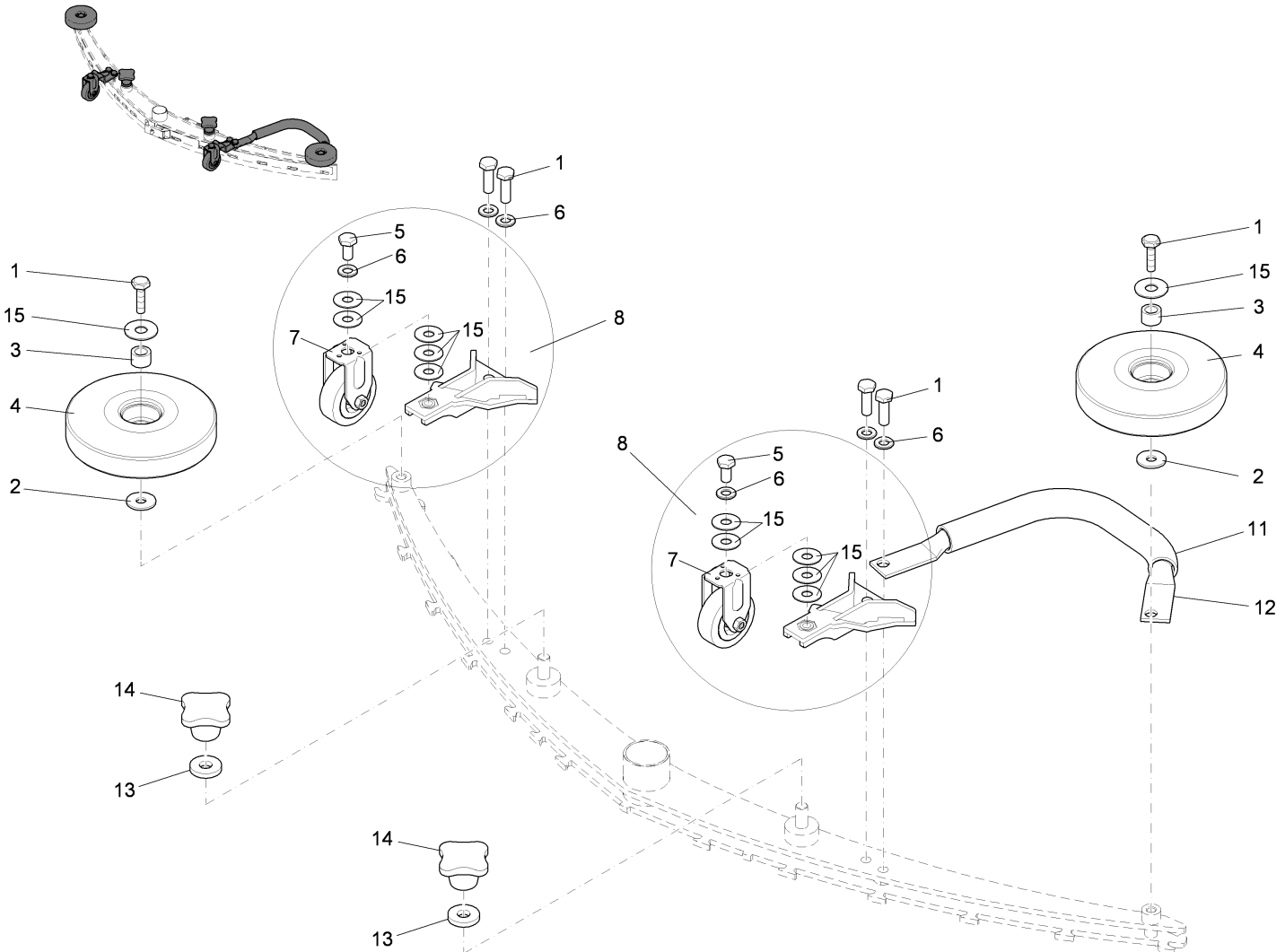

Squeegee Mechanism Assembly

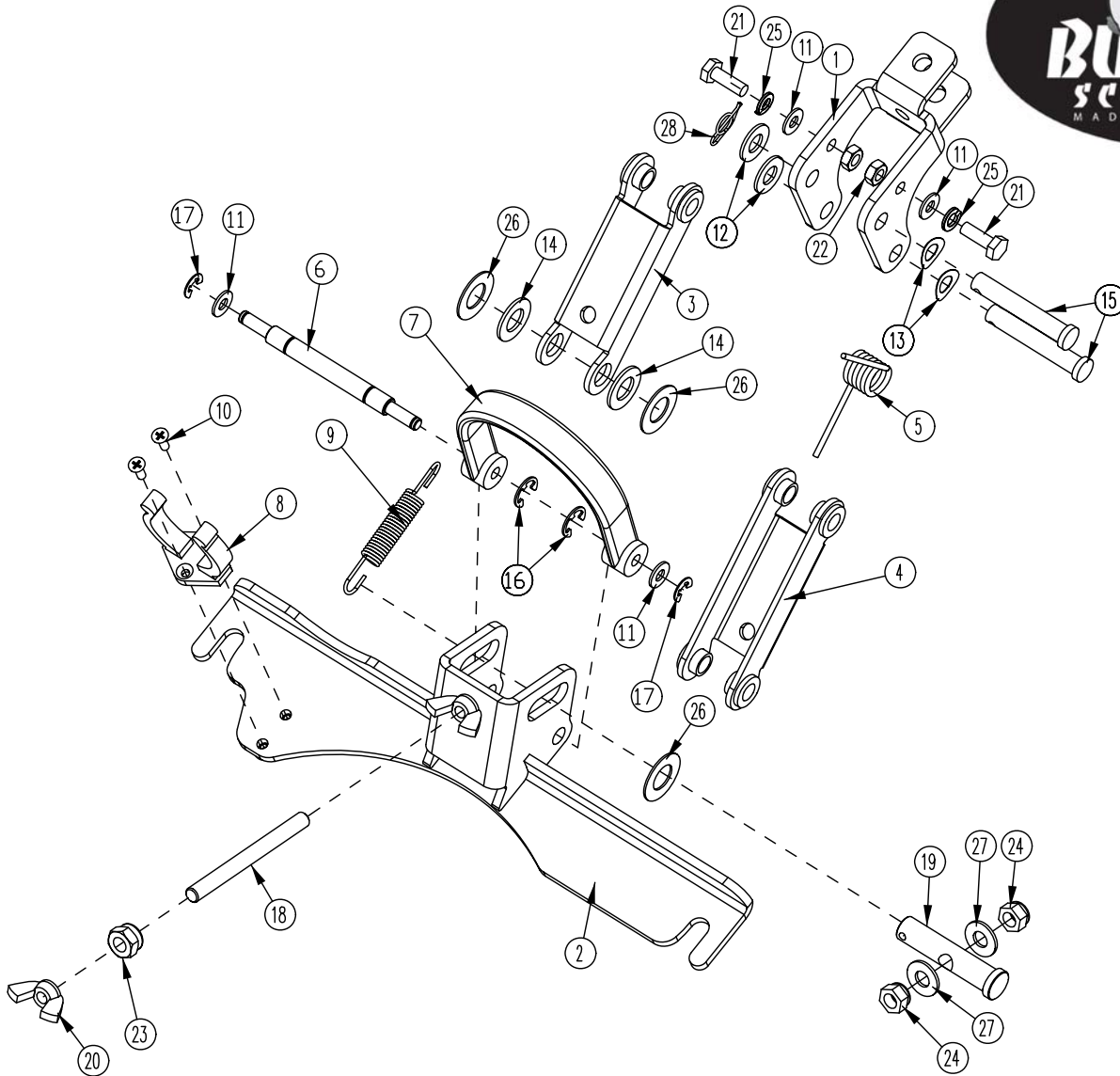

BILL OF MATERIAL - 172150

ITEM	PART NO.	REQ'D	DESCRIPTION	ITEM	PART NO.	REQ'D	DESCRIPTION
1	172134	1	BKT, MAIN SQUEEGEE HINGE	15	711678	2	CLEVIS PIN 3/8 X 2-1/4
2	172155	1	SQUEEGEE MOUNT WMT	16	711717	2	RETAINING RING- E TYPE .37
3	172196	1	SQ TOP LINK W/ BUSHING	17	711720	2	.250 DIA RETAINING RING- E TYPE
4	172197	1	SQ BOT LINK W/ BUSH	18	712147	1	ROD-THD 5/16-18 X 3.5 SS
5	172261	1	TORSION SPRING	19	712148	1	CLEVIS PIN, 1/2 x 2.25 W/ HOLE
6	172352	1	PIN, 3/8 X 3.0, SQG STRAP	20	712157	2	NUT- WING 5/16-18 SS
7	172357	1	STRAP, 9" PU, BLACK	21	712562	2	BOLT-HH 1/4-20X3/4 SS
8	260579	1	TOOL CLIP, 1.5" HOSE	22	712665	2	NUT-HEX 1/4-20 SS
9	430051	1	RETURN SPRING-3.00"	23	712680	1	NUT-HEX 5/16-18 SS
10	710530	2	SCR-MC FL HD 8-32 X .50 BRS	24	712683	2	NUT, HEX 5/16-18 NYLOC SS
11	711504	4	WSR-FLAT 1/4 ID SS	25	712758	2	WSR-HELICAL 1/4 SS
12	711515	2	WSR-FLAT .406 X .812 X .0625	26	712760	3	WSR-FLAT .56X1.06X.04 SS
13	711523	2	WSR-WAVE .37X .68 X .08	27	712772	2	WSR-FLAT .344 x .75 x .06 SS
14	711592	2	WSR-FLAT .506 X .9 X .064 NYL	28	3400125	1	PIN-COTTER 3/8 RUE RING

Optional Pump Kit

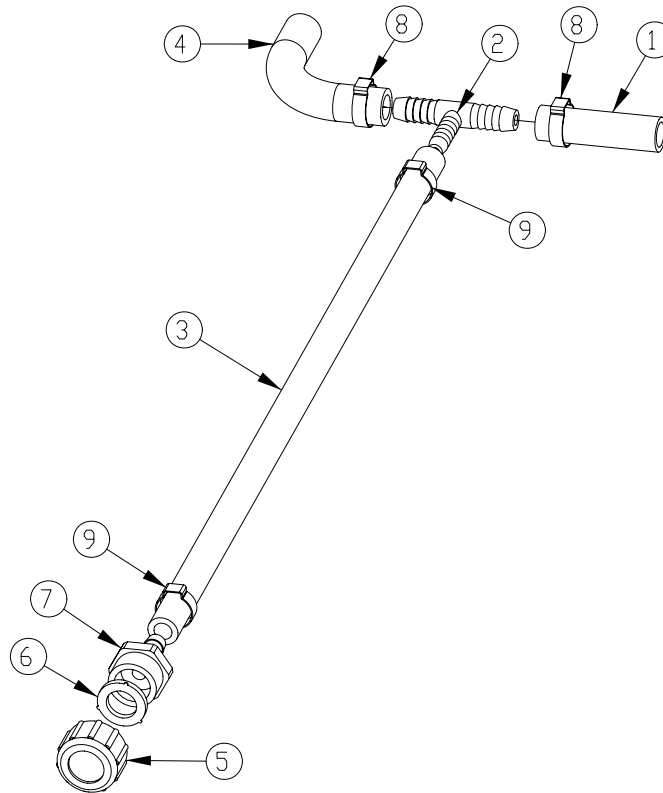

BILL OF MATERIAL - 172405			
ITEM	PART NO.	REQ'D	DESCRIPTION
1	172328	1	HOSE-NYLO REINF 1/2ID X 2.5"
2	172400	1	FITTING-T EE 1/2X1/2X3/8HB PP
3	172411	1	HOSE-WIRE REINF 3/8 X 18"
4	172428	1	HOSE-WIRE REINF 1/2 X 5.5."
5	200023	1	GARDEN HOSE CAP
6	200024	1	BLACK VINYL WASHER
7	342441	1	FITTING, MGHT X 3/8HB PP
8	383347	2	CRIMP CLAMP 1/2 HOSE SS 185R
9	450076	2	CLAMP-CRIMP 185R SS

1 Wiring Diagrams

PAGE LAYOUT



PAGES GO TOGETHER AS SHOWN TO SEE THE ENTIRE SCHEMATIC AS ONE.

ELECTRICAL BOX COVER ASSEMBLY 172330-26

715678: DIAGNOSTIC CODE DECAL

- DIAGNOSTIC CODES: BATTERY GAUGE: 747011
- 1 BAR : CHARGE BATTERIES
 - 2 BAR : DRIVE MOTOR CONNECTION
 - 3 BAR : DRIVE MOTOR SHORT CIRCUIT
 - 4 BAR : BATTERY LOCKOUT
 - 5 BAR : NOT USED
 - 6 BAR : DRIVE INHIBIT
 - 7 BAR : THROTTLE FAULT
 - 8 BAR : DRIVE CONTROLLER FAULT
 - 9 BAR : NOT USED
 - 10 BAR : EXCESSIVE BATTERY VOLTAGE

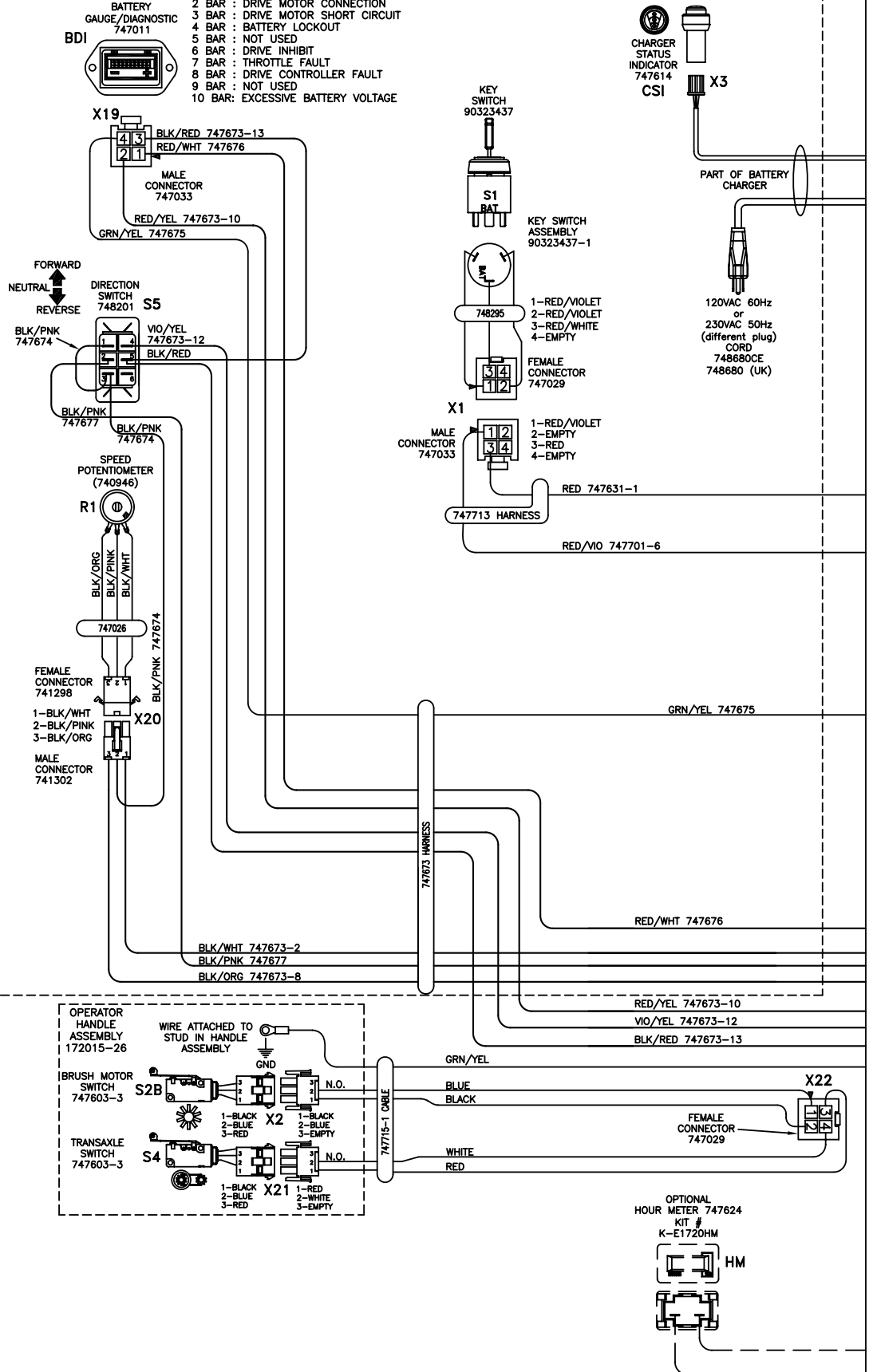

ELECTRICAL
BOX ASSEMBLY
172075-26

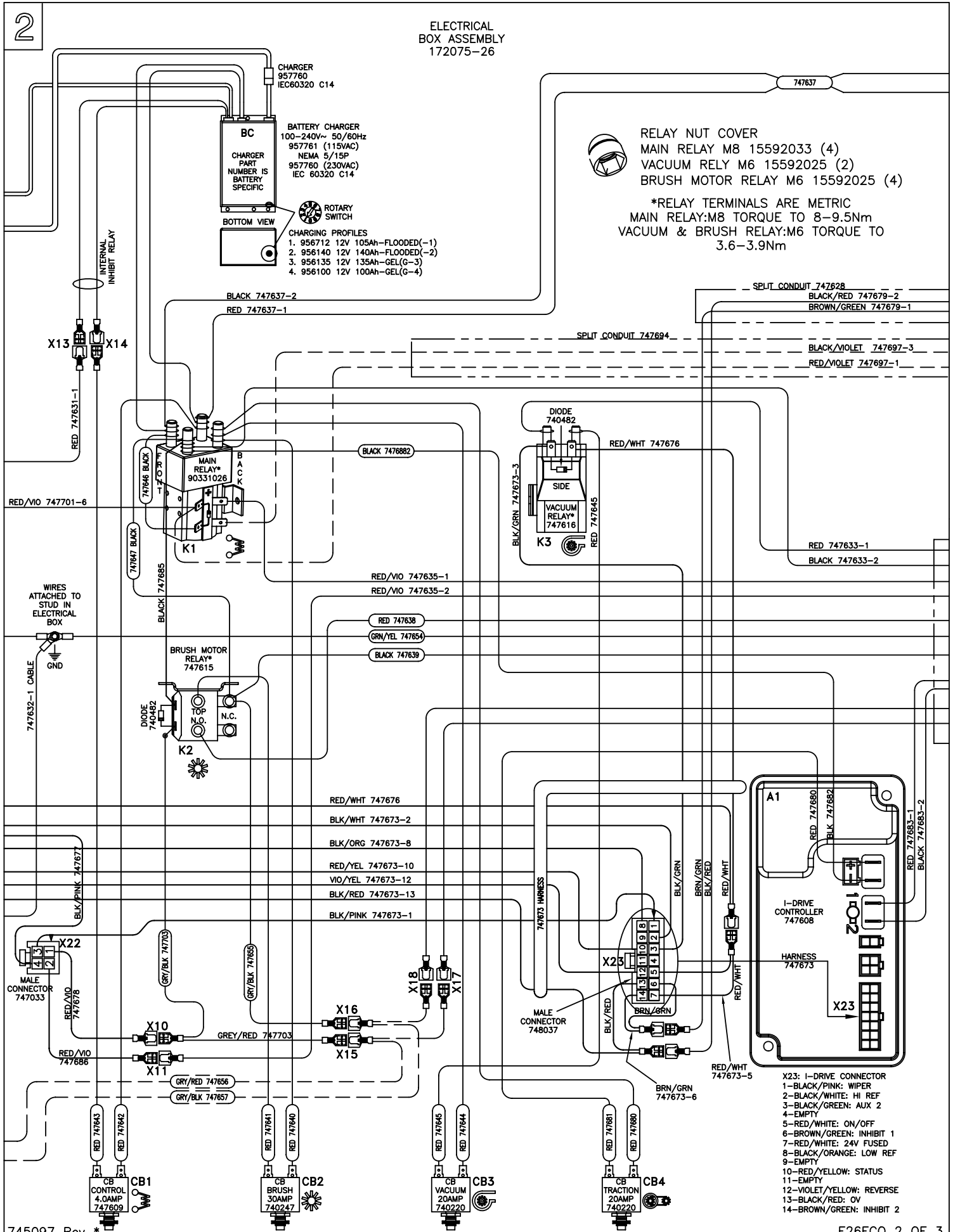

- RELAY NUT COVER
 MAIN RELAY M8 15592033 (4)
 VACUUM RELY M6 15592025 (2)
 BRUSH MOTOR RELAY M6 15592025 (4)
- *RELAY TERMINALS ARE METRIC
 MAIN RELAY:M8 TORQUE TO 8-9.5Nm
 VACUUM & BRUSH RELAY:M6 TORQUE TO 3.6-3.9Nm

CHARGER
957760
IEC60320 C14

BATTERY CHARGER
100-240V~ 50/60Hz
957761 (115VAC)
NEMA 5/15P
957760 (230VAC)
IEC 60320 C14

CHARGING PROFILES
 1. 956712 12V 105Ah-FLOODED(-1)
 2. 956140 12V 140Ah-FLOODED(-2)
 3. 956135 12V 135Ah-GEL(G-3)
 4. 956100 12V 100Ah-GEL(G-4)

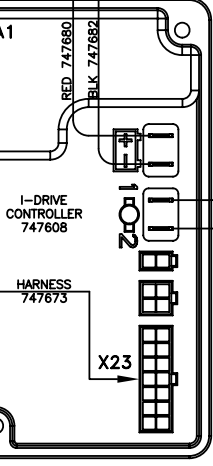

- X23: I-DRIVE CONNECTOR
 1-BLACK/PINK: WIPER
 2-BLACK/WHITE: HI REF
 3-BLACK/GREEN: AUX 2
 4-EMPTY
 5-RED/WHITE: ON/OFF
 6-BROWN/GREEN: INHIBIT 1
 7-RED/WHITE: 24V FUSED
 8-BLACK/ORANGE: LOW REF
 9-EMPTY
 10-RED/YELLOW: STATUS
 11-EMPTY
 12-VIOLET/YELLOW: REVERSE
 13-BLACK/RED: OV
 14-BROWN/GREEN: INHIBIT 2

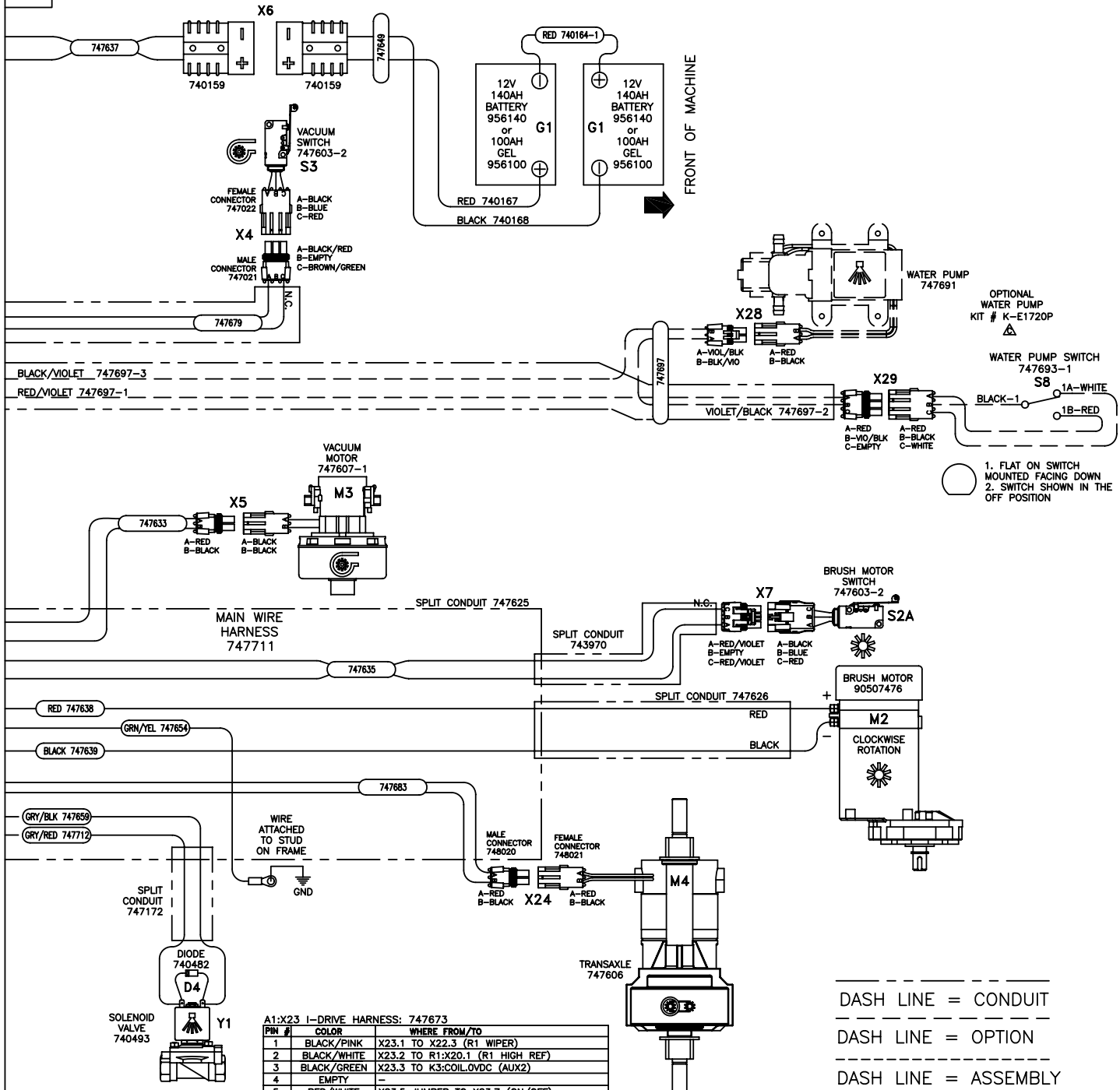

1. FLAT ON SWITCH MOUNTED FACING DOWN
2. SWITCH SHOWN IN THE OFF POSITION

DASH LINE = CONDUIT
DASH LINE = OPTION
DASH LINE = ASSEMBLY

A1:X23 I-DRIVE HARNESS: 747673

PIN #	COLOR	WHERE FROM/TO
1	BLACK/PINK	X23.1 TO X22.3 (R1 WIPER)
2	BLACK/WHITE	X23.2 TO R1:X20.1 (R1 HIGH REF)
3	BLACK/GREEN	X23.3 TO K3:COIL.OVDC (AUX2)
4	EMPTY	-
5	RED/WHITE	X23.5 JUMPER TO X23.7 (ON/OFF)
6	BROWN/GREEN	X23.6 JUMPER TO X23.14 (INHIBIT 1)
7	RED/WHITE	X23.7 JUMPER TO X23.5 (24VDC FUSED)
8	BLACK/ORANGE	X23.8 TO R1:X20.3 (R1 LOW-REF)
9	EMPTY	-
10	RED/YELLOW	X23.10 TO BD1:X19.2 (STATUS)
11	EMPTY	-
12	VIOLET/YELLOW	X23.12 TO S5.4 (REVERSE)
13	BLACK/RED	X23.13 JUMPER S5.5 JUMPER BD1:X19.3 (OV)
14	BROWN/GREEN	X23.14 JUMPER TO X23.6 (INHIBIT 2)

R1:X20 SPEED POTENTIOMETER: 747026

COLOR	WHERE FROM/TO
1	BLACK/WHITE X20.1 TO A1:X23.2
2	BLACK/PINK X20.2 TO S5.3 JUMPER S5.1
3	BLACK/ORANGE X20.3 TO A1:X23.8

X22: OPERATOR HANDLE CABLE: 747715-1

COLOR	WHERE FROM/TO
1	BLUE X22.1 TO S2B:X2.B
2	BLACK X22.2
3	RED X22.3 TO S4:X21.A
4	WHITE X22.4 TO S4:X21.B

X22: CONNECTOR TO OPERATOR HANDLE CABLE: 747715-1

COLOR	WHERE FROM/TO
1	RED/VIOLET X22.1 TO X10 JUMPER K2:COIL.24VDC JUMPER X15
2	RED/VIOLET X22.2 TO X11 TO S2A:X7.A
3	BLACK/PINK X22.3 TO A1:X23.1
4	BLACK/PINK X22.4 TO S5.2

S1:X1 MAIN KEYSWITCH ASSEMBLY: 90323437-1

PIN #	COLOR	WHERE FROM/TO
1	RED/VIOLET	X1.1 TO K1:COIL.24VDC
2	EMPTY	-
3	RED or RED/WHI	X1.3 TO X13 BC INTERNAL RELAY
4	EMPTY	-

BATTERY CHARGER: 957761 or 957760

COLOR	WHERE FROM/TO
X13	RED X13 TO S1:X1.1
X14	BLACK X14: CB1 CONTROL 4.0A
14GA	RED K1:CONTACT + (REAR LEFT POST)
14GA	BLACK K1:CONTACT - (FRONT LEFT POST)

OTHER WIRE COLORS

COLOR	WHERE FROM/TO
RED	BATTERY 24VDC: +
BLACK	BATTERY OVDC: -
GREEN/YELLOW	GROUND
RED/VIOLET	24VDC AFTER MAIN KEYSWITCH
GREY/RED	OPTIONAL POWER 24VDC: 4A MAX
X15	OPTIONAL POWER 24VDC: 4A MAX
X16	OPTIONAL POWER OVDC: 4A MAX
X8:A	VIOLET/BLACK WATER PUMP: 24VDC
X8:B	BLACK/VIOLET WATER PUMP: OVDC
X9:A	VIOLET/BLACK WATER SOLENOID VALVE: 24VDC
X9:B	BLACK/VIOLET WATER SOLENOID VALVE: OVDC

E26ECO PART REFERENCE LIST
Schematic 745097

REFERENCE #	COMPONENT NAME	PART NUMBER
M1 (optional)	not used	-
M2	MOTOR, BRUSH	90507476
M3	MOTOR, VACUUM ASSEMBLY	747607-1
M4	TRANSAXLE	747606
Y1	SOLENOID VALVE, WATER	740493
K1	RELAY, MAIN	90331026
K2	RELAY, BRUSH MOTOR	747615
K3	RELAY, VACUUM	747616
CB1	CIRCUIT BREAKER 4.0A, CONTROL	747609
CB2	CIRCUIT BREAKER 30A, BRUSH MOTOR	740247
CB3	CIRCUIT BREAKER 20A, VACUUM MOTOR	740220
CB4	CIRCUIT BREAKER 20A, TRANSAXLE	740220
S1	KEYSWITCH	747617
S2A	SWITCH, BRUSH MOTOR (at motor)	747603-2
S2B	SWITCH, BRUSH MOTOR (handle)	747603-3
S3	SWITCH, VACUUM MOTOR	747603-2
S4	SWITCH, TRANSAXLE (handle)	747603-3
S5	SWITCH, DIRECTION	748201
S8 (optional)	not used	-
A1	CONTROLLER, I-DRIVE	747710
R1	SPEED POTENTIOMETER ASSEMBLY	747026
BDI	BATTERY DISCHARGE INDICATOR	747011
CSI	CHARGER STATUS INDICATOR	747614
HM (optional)	HOUR METER (KIT K-E1720HM)	747624
BC (model specific)	BATTERY CHARGER 115VAC (battery type specific)	957761 (-2 or G-4)
BC (model specific)	BATTERY CHARGER 230VAC (battery type specific)	957760 (-2 or G-4)
G1	BATTERY, 12V 140AH (2 REQUIRED)	956140
G1 (optional)	BATTERY, GEL 12V 100AH (2 REQUIRED)	956100
D1	DIODE, MAIN RELAY	Part of K1
D2	DIODE ASM, BRUSH MOTOR RELAY	740482
D3	DIODE ASM, VACUUM MOTOR RELAY	740482

REFERENCE #	CONNECTOR FUNCTION	PART # -female	PART # -male
X1	KEYSWITCH (S1)	744012	748037
X2	SWITCH, BRUSH MOTOR (S2B)	747022	747021
X3	CHARGER STATUS INDICATOR (CSI)	Part of CSI	Part of BC
X4	SWITCH, VACUUM (S3)	747022	747021
X5	MOTOR, VACUUM (M3)	748021	748020
X6	BATTERY CONNECTOR	740159	740159
X7	SWITCH, BRUSH MOTOR (S2A)	747022	747021
X8 (optional)	not used	-	-
X9	not used	-	-
X10	OPERATOR HANDLE CABLE	741093	740697
X11	OPERATOR HANDLE CABLE	740366	740697
X13	BATTERY CHARGER (BC)- INTERNAL RELAY	740366	740697
X14	BATTERY CHARGER (BC)-INTERNAL RELAY	740366	740697
X15	SOLENOID (Y1) /HOUR METER CONNECTION (HM)	740366	741165
X16	SOLENOID (Y1) /HOUR METER CONNECTION (HM)	740366	741165
X17 (optional)	OPTIONAL HOUR METER (HM) WIRE-747656	740366	741165
X18 (optional)	OPTIONAL HOUR METER (HM) WIRE-747657	740366	741165
X19	BATTERY GAUGE (BDI)	Part of BDI	747033
X20	SPEED POT ASSEMBLY (R1)	741298	741302
X21	SWITCH, TRANSAXLE (S4)	747022	747021
X22	OPERATOR HANDLE CABLE: 747632-1	747029	747033
X23	I-DRIVE HARNESS: 747673	Part of A1	748037
X24	TRANSAXLE (M4)	748021	748020
X25	I-DRIVE (A1) TO VACUUM SWITCH (S3)	740366-1	741165
X26	I-DRIVE (A1) TO VACUUM SWITCH (S3)	741093	740698
X27	I-DRIVE (A1) TO VACUUM RELAY-CONTACT	741093	741165
X28 (optional)	not used	-	-
X29 (optional)	not used	-	-