

PowerBoss[®]
The Power of Clean

**User Manual
Nautilus E
Battery Operated
Rider Scrubber\Sweeper**

Model: SM45DQP



PowerBoss[®], Minuteman International, Inc.
A Member of the Hako Group

#988768UM-D Rev. B 11/20

PREFACE

Thank you for your purchase of the new industry standard for scrubber/sweepers. PowerBoss® takes great pride in offering the most dependable, reliable and best value in industrial power scrubbers and sweepers. We set the standard.

Our Customer Service Department would like to hear from you. If you see any errors, omissions or something that needs clarification in this User Manual, please let us know. We are working hard towards continually improving our processes--to benefit you, our valued customer.

Please copy the form below, fill out and comment on how you found our manual.

Thank you!

The PowerBoss Team

Name: _____

Title: _____

Company Name: _____

Address: _____

Country: _____

Type of equipment or model number: _____

Comments: _____

Please return to:

Customer Service Manager

PowerBoss®, Minuteman International, Inc.

14N845 U.S. Route 20

Pingree Grove, Illinois 60140 USA

Phone: (800) 323-9420

Email: tech@powerboss.com

This is the User Manual for the PowerBoss® Nautilus E Disc Rider Scrubber/Sweeper.

This manual covers all Standard Nautilus E machine variations beginning April 2020.

We believe this machine will provide excellent service for many years.

However, the best results will be obtained if:

- The machine is operated with reasonable care.
- The machine is maintained regularly per the maintenance schedule provided in this User Manual.
- The machine is maintained with PowerBoss® supplied or equivalent parts.

All right side and left side references to the machine are determined by facing the direction of forward travel. Some hardware considered to be common or locally available has been omitted from the parts section to make this manual clear. Be sure to use equivalent hardware when replacement becomes necessary.

The Model and Serial Number of your machine is shown on the I.D. name plate. This information is needed when contacting Technical Support or when ordering parts. The I.D. plate is mounted on the left side wall of the operator seating area.

Example I.D. Plate:

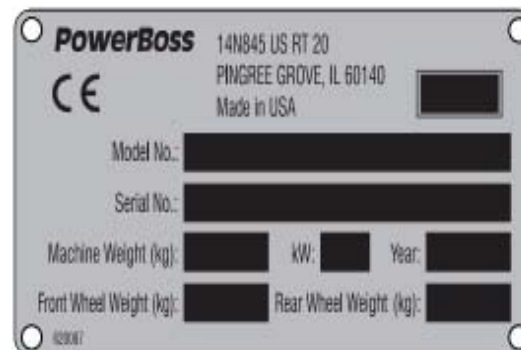

Parts may be ordered by phone, fax or e-mail from your local PowerBoss® parts and service center. Before ordering parts or supplies, be sure to have your machine Model Number and Serial Number handy. For your convenience Fill out the Machine Data block for future reference.

MACHINE DATA Fill out at installation	
Model Number:	_____
Serial Number:	_____
Sales Rep.:	_____ Date of Install: _____

All information contained in this catalog is current at the time of printing.
Minuteman International, Inc. reserves the right to make changes at any time without notice.

PowerBoss®, Minuteman International, Inc., Copyright 2014-2015, Printed in USA

TECHNICAL SPECIFICATIONS

Model: Nautilus E Battery Operated Disc Rider Scrubber/Sweeper

Model No.: SM45DQP, SM45DQP-CE

Integrated Cleaning System Nautilus E HD Disc Scrubber	
Scrubbing Path (main scrub deck) with scrubbing side brush	45 in / 1,143 mm 55.5 in / 1,409.7
Direct Throw Sweeping Path (main broom)	45 in / 1,143 mm
Direct Throw Sweeping Path (main broom & side brooms)	73 in / 1,854.2
Disk brush speed	350 rpm
Disk brush down force (up to)	400 lb / 181 kg
Brush motor power	(3) @ 1.25 hp
Solution tank	90 gal / 341 L
Recovery tank (including demister chamber)	104 gal / 394 L
Debris capacity maximum direct throw	3 ft ³ / 85 L
Vacuum fan power	(2) @ .8 hp
Vacuum fan speed	14,500 rpm
Vacuum water lift	65 in / 1,651 mm
PROPELLING SYSTEM	
Propel speed forward (transport variable to)	5.5 mph / 8.9 kph
Propel speed forward (scrubbing variable to)	4 mph / 6.4 kph

Dual Force Gradeability - Working Transport	3 degrees/5% 9.7 degrees/17%
*sweep hopper must be lifted prior to going on a 5° ramp	
BATTERY SELECTIONS	
Standard battery	750 AH C6
Opt. battery (opportunity charge capable)	840 AH C6
Opt. battery (opportunity charge capable)	864 AH Lithium
MACHINE SPECIFICATIONS	
Length basic machine	109.6 in / 2,784 mm
Width, body	63 in / 1,600 mm
Width, including side scrub	65.75 in / 1,670 mm
Height (top of tank)	58.1 in / 1,476 mm
With overhead guard	80 in / 2,032 mm
Weight empty (no battery)	
Minimum aisle turn	118.25 in / 3,003 mm
Ground Clearance	2.5 in / 64 mm

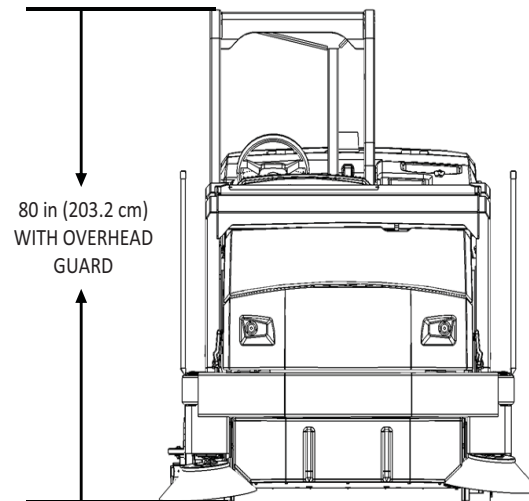
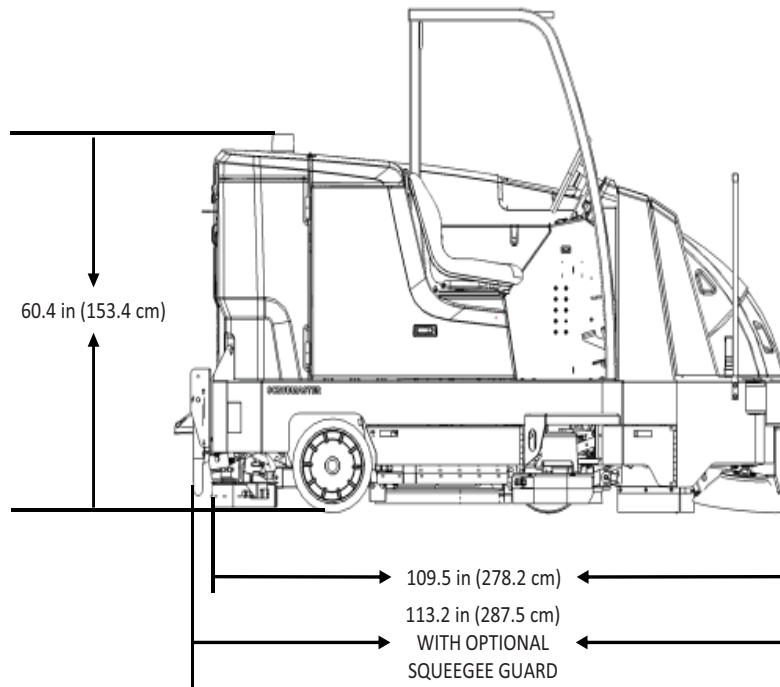
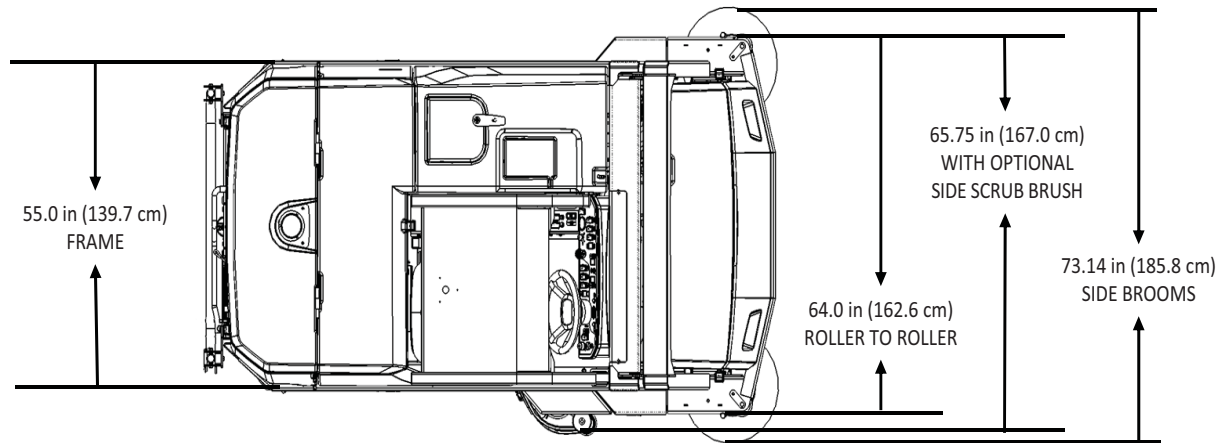

CE DECLARATION OF CONFORMITY

14N845 U.S. Route 20 · Pingree Grove, Illinois 60140 USA
Phone: 800-323-9420 · Fax: 847-683-5207
A Member of the Hako Group

PowerBoss®
The Power of Clean

- D EG-Konformitätserklärung (entsprechend der EG-Richtlinie 2006/42/EG)
- GB EC Declaration of Conformity (according to Directive 2006/42/EC)
- F Déclaration de conformité pour la CEE (conforme à la directive de la CEE 2006/42/CEE)
- I Dichiarazione CE di Conformità (ai sensi della direttiva CEE 2006/42)
- E CEE Declaración de Conformidad (según la normativa de la CEE 2006/42/CE)

PowerBoss Inc. erklären in alleiniger Verantwortung, daß das Produkt,
declare under our sole responsibility, that the product,
declérons sous notre seule responsabilité que le produit,
Dichiara sotto la propria responsabilità che il prodotto,
declaramos bajo responsabilidad propia que el producto,

Machine Nautilus Electric Scrubber/Sweeper - SM45C-CE, SM45D-CE

D auf das sich diese Erklärung bezieht, den einschlägigen grundlegenden Sicherheits- und Gesundheitsanforderungen der EG-Richtlinie 2006/42/EG, sowie den Anforderungen gemäß 2014/30/EG entspricht. Zur sachgerechten Umsetzung der in den EG-Richtlinien genannten Sicherheits- und Gesundheitsanforderungen wurde(n) folgende Norm(en) und /oder technische Spezifikation(en) herangezogen:

GB to which this declaration relates corresponds to the relevant basic safety and health requirements of the Directive 2006/42/EC, and to the requirements of the other relevant Directives 2014/ 30 /EC. For the relevant implementation of the safety and health requirements mentioned in the Directives, the following standard(s) and/or technical specification(s) has (have) been respected:

Faisant l'objet de la déclaration est conforme aux prescriptions fondamentales en matière de sécurité et de santé stipulées dans la Directive de la CEE 2006/42/CEE, ainsi qu'aux prescriptions des autres Directives de la CEE établies dans ce domaine 2014/ 30 /CEE. Pour mettre en pratique dans les règles de l'art les prescriptions en matière de sécurité et de santé stipulées dans les Directives de la CEE, il a été tenu compte de la/des norme(s) et/ou de la/des spécification(s) technique(s) suivante(s):

È conforme ai requisiti essenziali di sicurezza e di tutela della salute di cui alla Direttiva CEE 2006/42 e sue successive modifiche, nonché ai requisiti di cui alle seguenti Direttive CEE 2014/ 30 . Per la verifica della Conformità di cui alle Direttive sopra menzionate, sono state consultate le seguenti, Norme Armonizzate EN:

El cual se refiere la presente declaración corresponde a las exigencias básicas de la normativa de la CEE 2006/42/CE y referentes a la seguridad y a la sanidad, así como a las exigencias de la demás normativas de la CEE 2014/ 30 /CE. Con el fin de realizar de forma adecuada las exigencias referentes a la seguridad y a la sanidad mencionadas en las normativas de la CEE fue(ron) consultada(s) la(s) siguiente(s) normativa(s) y especificación(es) técnicas(s):

Date 23 September 2020

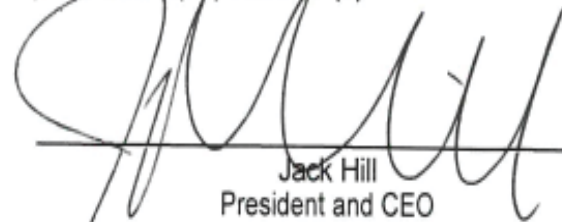

Jack Hill
President and CEO

Name der autorisierten Person, die für PowerBoss die technischen Unterlagen zusammenstellt:
Name of the person authorized for PowerBoss to compile the technical file:
Personne chargée du suivi du dossier technique:
Nome della persona autorizzata da PowerBoss a compilare il file tecnico:
Nombre de la persona autorizada por PowerBoss para la creación del fichero técnico: Sebastien Filippone

D, GB, F, I, E

TABLE OF CONTENTS

PREFACE 2

TECHNICAL SPECIFICATIONS 6

CE DECLARATION OF CONFORMITY 8

FEATURES 14

 AIR-MOVING SYSTEM 14

 ERGONOMICS SYSTEM 14

 CHASSIS SYSTEM 14

 MULTI-LEVEL HOPPER DUMP SYSTEM 14

 ENVIRONMENTAL FRIENDLY FEATURES 14

 SAFER WORK ENVIRONMENT 14

SAFETY INFORMATION 14

 IMPORTANT SAFETY INSTRUCTIONS 14

 FOR SAFETY DURING OPERATION 15

 SAFETY WHEN SERVICING OR MAINTAINING 15

 SAFETY SYMBOLS 16

 SAFETY DECALS 17

BASIC POWERBOSS® SAFETY 19

MACHINE OPERATION 22

 OPERATING CONTROLS AND INDICATORS 22

 KEY SWITCH 22

 LIGHT SWITCH 22

 HORN BUTTON 22

INSTRUMENT PANEL CONTROL SWITCHES ... 22

 INDICATOR LIGHTS 24

 RECOVERY TANK FULL INDICATOR 24

 SOLUTION TANK EMPTY INDICATOR 24

 BATTERY DISCHARGE INDICATOR 24

 DIRECTIONAL CONTROL SWITCH 26

 BRAKE / PARKING BRAKE 26

 CIRCUIT BREAKERS 26

 HOUR METER 26

 SEAT ADJUSTMENT 26

 SPEED CONTROL PEDAL 26

 GREEN “ONE-TOUCH” SWITCH 27

 SQUEEGEE SWITCH 27

 SCRUB BRUSHES SWITCH 27

 SIDE SCRUB BRUSH SWITCH - OPTION 27

DOWN PRESSURE SWITCH.....	28	RAISING THE BUMPER.....	40
SOLUTION CONTROL KNOB	28	EMPTYING/CLEANING THE DEBRIS HOPPER	41
HOPPER DOOR SWITCH.....	28	HOPPER FILTER REMOVAL	42
HOPPER SAFETY BUTTON (OPTION).....	29	FILTER CLEANING	42
MAIN BROOM SWITCH	29	FILTER REPLACEMENT.....	42
SIDE BROOM SWITCH.....	29	DRAINING THE SOLUTION TANK	44
VACUUM FILTER SWITCH.....	29	OPERATING PROCEDURES.....	45
FILTER SHAKER SWITCH.....	29	PRE-OPERATION CHECKS.....	45
BASIC SCRUBBING/FILLING/EMPTYING		STARTING	45
INFORMATION	30	DRIVING.....	45
CHOOSING THE CORRECT TYPE OF BRUSH.....	30	SLOWING AND STOPPING	46
FILLING THE SOLUTION TANK.....	32	INCLINES OR SLIPPERY SURFACES	46
FILLING THE SOLUTION TANK.....	33	STOP THE MACHINE	46
SWEEPING	34	TRANSPORTING THE MACHINE	46
NORMAL SCRUBBING	34	USING A TRAILER OR TRANSPORT VEHICLE	46
DOUBLE SCRUBBING	36	OPTIONS	47
STOP SCRUBBING.....	37	CHEMICAL METERING	47
WATER PICK UP MODE (SQUEEGEE ONLY).....	38	AUTO-FILL	48
STOP WATER PICK UP	38	OPERATOR SEAT SENSOR (CE)	48
DRAINING/CLEANING THE RECOVERY TANK	39	SPRAY AND VACUUM WAND	49

SUSPENSION SEAT 51
SIDE SCRUB BRUSH 52
SEAT BELTS 52
LIGHTS 52

PREVENTATIVE MAINTENANCE 54

ELECTRICAL SYSTEM 58
LUBRICATION POINTS 60
LATCHES & HINGES 61
GROUNDING CHAIN 63
HYDRAULIC SYSTEM 63
SCRUBBING COMPONENTS 64
SWEEP COMPONENTS 68
SIDE SCRUB BRUSH (OPTION) 72
SQUEEGEES 73
SIDE SQUEEGEES 78
SIDE SCRUB BRUSH SQUEEGEE (OPTION) 79
SKIRTS AND SEALS 80
BRAKES 81
DRIVE WHEEL MOTOR 82

REAR TIRES 82
SEAT MOUNT ADJUSTMENT: 83
SOLUTION DELIVERY BAR & FILTER SYSTEM 84

TROUBLESHOOTING 86

FEATURES

AIR-MOVING SYSTEM

- Internal sound insulation on vacuum impeller

ERGONOMICS SYSTEM

- Roomy, open operator compartment for extra comfort
- Toe operated parking brake
- Adjustable, high-back seat
- Power steering
- Unparalleled maintenance accessibility, hinged sides and covers require no tools.

CHASSIS SYSTEM

- Massive One-Piece, unitized 7ga, 0.188 in (0,48 cm) thick steel frame
- Soft-ride tires

MULTI-LEVEL HOPPER DUMP SYSTEM

- Debris hopper can be emptied from ground level up to 60" height.
- No need to hand dump debris hopper

ENVIRONMENTAL FRIENDLY FEATURES

SAFER WORK ENVIRONMENT

Orange machines are highly visible to others in the workplace, simple controls reduce operator error. Machine is equipped with a horn and an effective braking system. Some Safety Options available are: Overhead Guard, Backup Alarm, Safety Lights, and Fire Extinguisher.

SAFETY INFORMATION

IMPORTANT SAFETY INSTRUCTIONS

Operators must read and understand this manual before operating or maintaining this machine.

Do not operate this machine in flammable or explosive areas.

This machine is designed solely for removing dirt, dust and debris in an outdoor or indoor environment. PowerBoss does not recommend using this machine in any other capacity.

The following information indicate a potential hazard to the operator and equipment. Read this manual carefully and be aware when these conditions can exist. Take necessary steps to locate all safety devices on the machine and train the personnel operating the machine. Report any machine

damage or faulty operation immediately. Do not use machine if it is not in proper operating condition.

FOR SAFETY DURING OPERATION

Keep hands and feet clear of moving parts while machine is in operation.

Make sure all safety devices are in place and operate properly. All covers, doors and latches must be in place, closed and fastened before use.

During operation, attention should be paid to other persons in the work area and especially if small children are present.

Components can cause an explosion when operated near explosive materials or vapor. Do not operate this machine near flammable materials such as solvents, thinners, fuels, grain dust, etc.

Store or park this machine on a level surface only. To prevent unauthorized use, machine should be stored or parked with

the parking brake set and the key removed.

This machine is designed for level operation only. Do not operate on ramps or inclines greater than 14 degrees (24.9% grade).

This machine is not suitable for picking up hazardous dusts.

Use caution when moving this machine into areas that are below freezing temperatures.

SAFETY WHEN SERVICING OR MAINTAINING THE MACHINE

Stop on level surface, set parking brake and turn off machine.

Disconnect the power to the machine when servicing.

Avoid moving parts. Do not wear loose jackets, shirts, or sleeves when working on machine.

Avoid contact with battery acid. Battery acid can cause burns. When working on or around batteries, wear protective clothing and safety glasses. Remove metal jewelry. Do not lay tools or metal objects on top of battery.

Authorized personnel must perform repairs and

maintenance. Use PowerBoss supplied replacement parts.

SAFETY SYMBOLS

Five symbols are used throughout this manual to emphasize various levels of safety information. These symbols and the meaning of each are listed below.

DANGER

To warn of immediate hazards which will result in severe personal injury or death

WARNING

To warn of hazards or unsafe practices which could result in severe personal injury or death.

CAUTION

To warn of hazards or unsafe practices which could result in minor personal injury.

ATTENTION!

To warn of practices which could result in extensive equipment damage.

NOTE: To direct your attention to important equipment information or special instructions for preventing damage to equipment

Symbols at the top of the list are the strongest warnings. However, all symbols represent important information which should be observed to protect you and others from harm and injury, and to prevent damage to the equipment.

SAFETY DECALS

Decals directly attached to various parts of the unit are highly visible safety reminders which should be read and observed. Make sure the decals are replaced if they become illegible or damaged.

Safety decals located in the Operator compartment area:

#3342264:



(Read Manual)

#3301854:



#715967:



Safety decals located on the outside of the machine:

#3342650



(Pinch Point)

#715963



Safety Decal on inside of Recovery Tank Cover:

#715965



Safety decals on inside of Main Brush Side Doors:

#715968

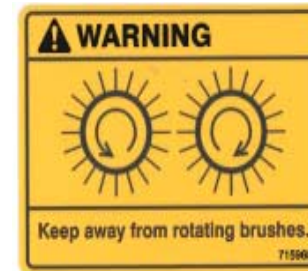

Safety decal located in the compartment area:

#3301730:



BASIC POWERBOSS® SAFETY

PowerBoss® scrubbers should never be operated unless:

1. The operator is trained and authorized to operate the equipment and,
2. The equipment is functioning correctly.
Malfunctioning equipment should be removed from service.

DANGER

Keep cigarettes, matches and all other flame sources away from the machine. Lead acid batteries are dangerous due to the highly explosive hydrogen gas they emit.

WARNING

Before turning on the machine, make sure that:

- * You have read and understood this User Manual
- * You are securely seated in the operator's seat.
- * The parking brake is engaged.

WARNING

During operation:

- * Keep your hands and body clear of moving parts, especially when the bumper is partially or fully raised.
- * Make sure others in the area stay clear of the machine, equipment, and moving parts.

⚠ WARNING

When leaving the scrubber unattended:

- * Place the controls in the OFF position.
- * **SET THE PARKING BRAKE.**
- * Remove the key.

⚠ WARNING

During cleaning and maintenance:

- * Always turn off the machine and set the parking brake before servicing.
- * Never use detergents or cleansers that are flammable or combustible.
- * Never inflate a pneumatic tire without using a safety
- * Always engage the bumper safety arm before servicing the hopper. Do not rely on the gas struts to keep the bumper raised.
- * Always engage the safety arm before servicing the hopper.
- * Never test for hydraulic hose leaks using your hand or any other part of your body. High pressure leaks can be very dangerous and should only be checked using a piece of paper.

⚠ WARNING

Replace any defective safety components before operating the scrubber.

⚠ WARNING

When servicing or working around or under raised hopper:

- * Install the hopper safety arm.

⚠ CAUTION

Do not drive with the hopper in the raised position. Driving with the hopper raised increases the risk of damaging the hopper and other hazards.

⚠ CAUTION

Travel slowly on grades.

⚠ CAUTION

Place a block or chock behind the wheels when parking on inclines.

⚠ CAUTION

Use special care when traveling on wet surfaces.

⚠ CAUTION

Observe all proper procedures for operation and maintenance of the unit, as outlined in this manual.

⚠ CAUTION

Remain alert at all times to people and equipment in and around your area of operation.

ATTENTION!

Never push or tow this machine faster than 1 mph (1,6 km/h).

MACHINE OPERATION

OPERATING CONTROLS AND INDICATORS

The right dark gray portion of the instrument panel contains the machine function switches and indicators.

The left light gray portion of the instrument panel contains the scrubbing function switches and indicators.

KEY SWITCH

The key switch is located to the right of the steering column and is used to start and stop the machine.

LIGHT SWITCH

The light switch is located on the left side of the operator compartment. It operates the head lights and tail lights.

HORN BUTTON

The horn is activated by pressing the horn button which is located to the right of the steering column below the throttle switch.

INSTRUMENT PANEL CONTROL SWITCHES

The main scrubbing controls are located on the main instrument panel for easy access and operator identification. See additional information on the Instrument Panel Control Switches.

DOWN PRESSURE SWITCH

This three position switch controls the amount of scrubbing pressure being applied to the cleaning surface.

GREEN “ONE TOUCH” SWITCH

A green “One-Touch” switch operates the entire scrubbing function.

SQUEEGEE SWITCH

This switch operates the Squeegee and Vac Fan.

SCRUB BRUSHES SWITCH

This switch operates the Scrub Brushes.

SIDE SCRUB BRUSH SWITCH - OPTION

This switch operates the Side Scrub Brush.

SOLUTION FLOW SWITCH

This switch controls the Solution Flow and has three settings: Off, Normal, and High.

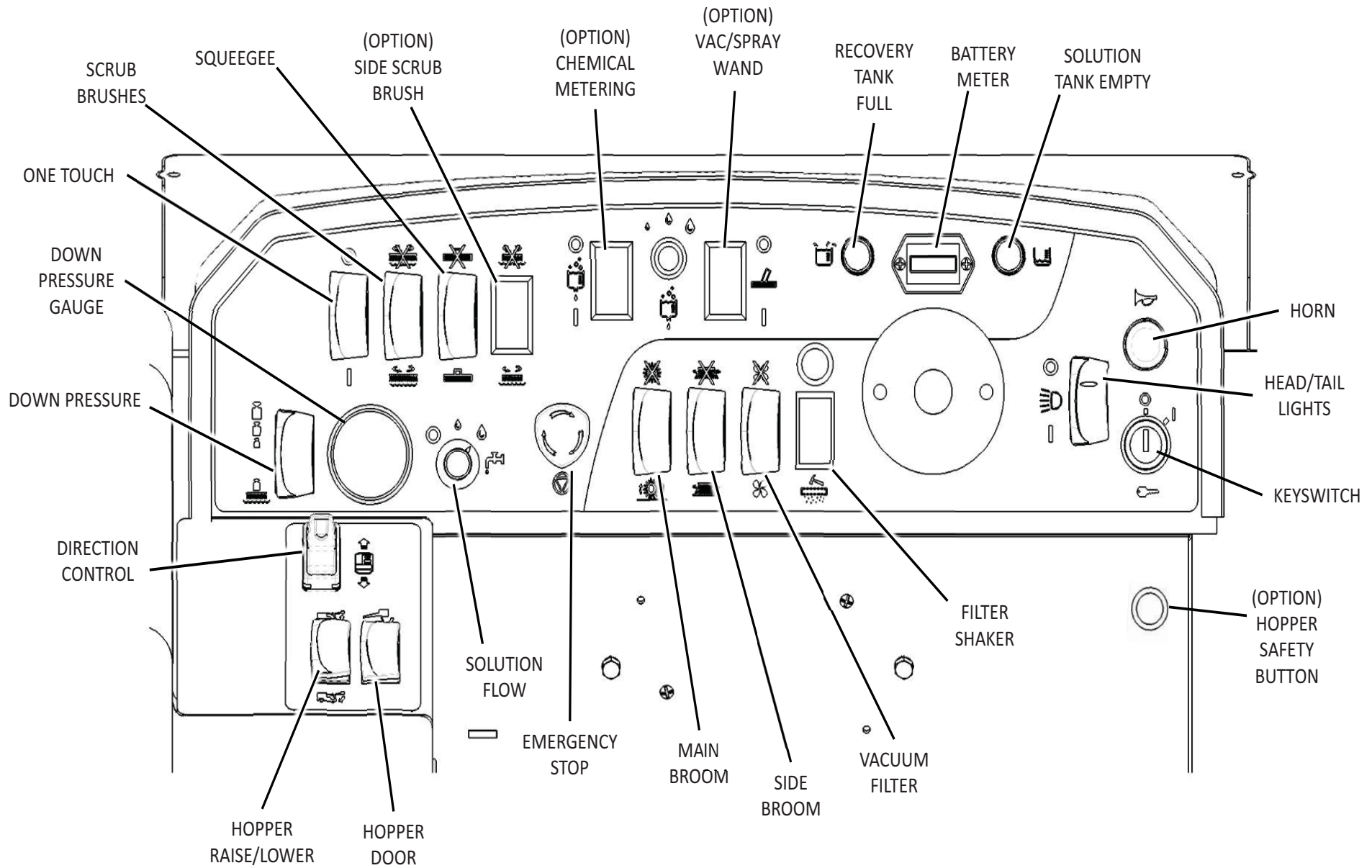

HOPPER RAISE/LOWER SWITCH

This switch controls the raising and lowering of the hopper.

HOPPER DOOR SWITCH

This switch controls the door for the hopper for dumping of collected debris.

MAIN BROOM SWITCH

This switch controls the Main Sweeping Broom.

SIDE BROOM SWITCH

This switch controls the Side Broom.

VACUUM FILTER SWITCH

This switch controls the Vacuum Filter.

FILTER SHAKER SWITCH

This switch controls the Hopper Filter Shaker.

HOPPER SAFETY BUTTON (OPTION)

This button is a safety option to ensure safety when lowering the hopper. (Standard on CE machines)

CHEMICAL METERING FLOW SWITCH - OPTION

This switch controls the Chemical Metering Flow and has three settings: Low, Medium, and High.

VAC AND SPRAY WAND SWITCH - OPTION

This switch operates the Vac and Spray Wand.

INDICATOR LIGHTS

RECOVERY TANK FULL INDICATOR

When the recovery tank is nearly full the red “full recovery tank” indicator lamp on the instrument panel will begin to blink on and off. When the lamp stops blinking and remains illuminated the tank is full. A few seconds later the scrubbing and squeegee systems automatically shut off and all components are raised to their stored positions. The vacuum fan will continue to operate for a short time.

SOLUTION TANK EMPTY INDICATOR

When the solution tank is nearly empty a red indicator lamp on the instrument panel will blink on and off. When the lamp stops blinking and remains illuminated there is solution remaining for approximately 10 minutes of scrubbing time.

BATTERY DISCHARGE INDICATOR

The battery discharge indicator displays the charge level of the batteries while the machine is operating.

When the batteries are fully charged, all five bars are lit. Recharge the batteries when there is only one bar shown in the display. Do not allow the batteries to discharge below 20% (last bar).

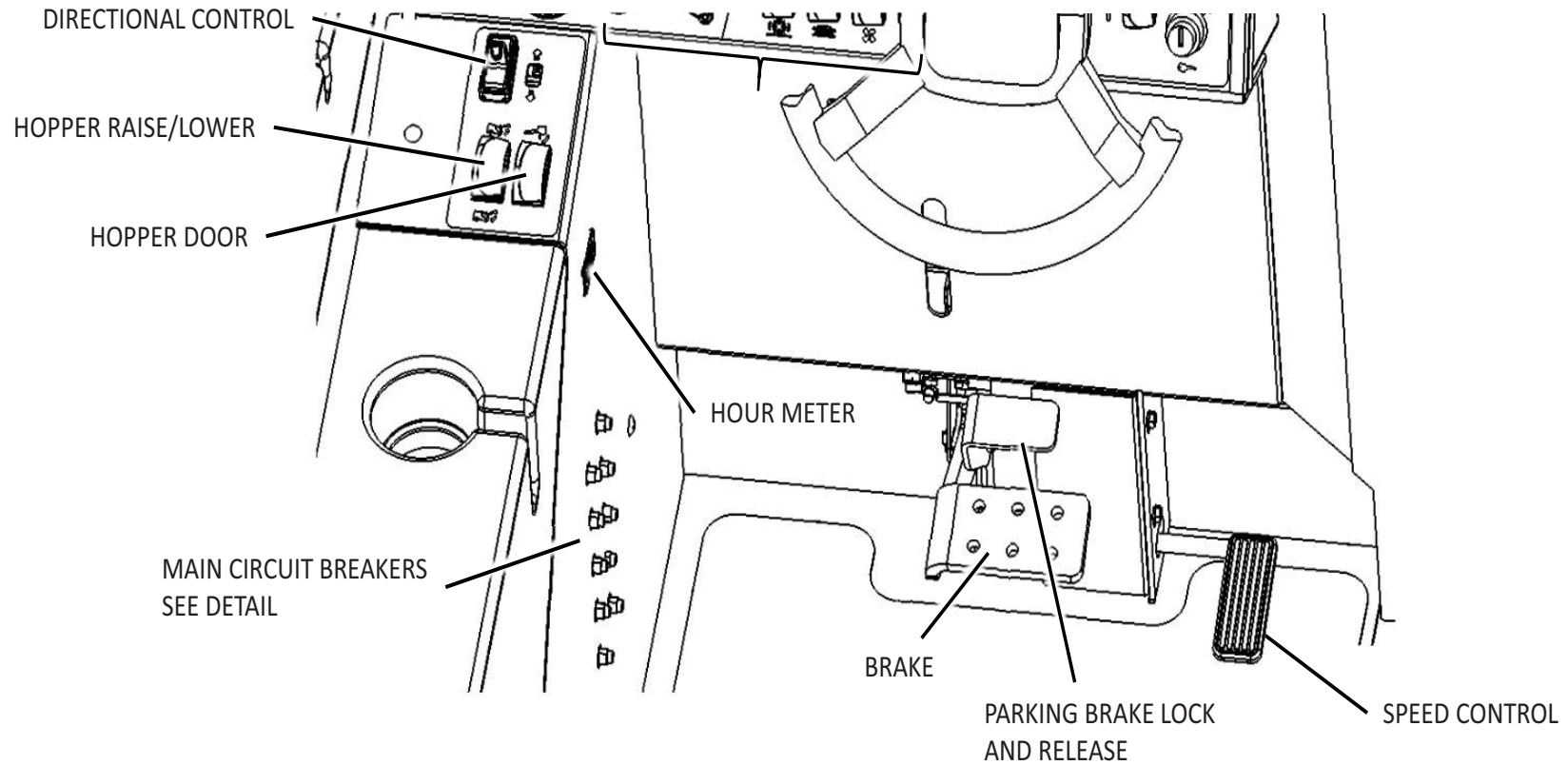

DIRECTIONAL CONTROL SWITCH

The directional control switch is used to control the direction of the machine in either forward or reverse.

- To propel the machine forward, push the switch forward.
- To propel the machine backward, push the switch down.

BRAKE / PARKING BRAKE

The mechanical drum brakes on the two rear wheels are operated by pressing on the brake pedal. To engage the parking brake push on the brake pedal then depress the upper brake lock to set the parking brake. To release the parking brake depress the brake pedal

CIRCUIT BREAKERS

The Circuit Breakers are located on the lower left wall of the operator compartment, and electrical box. To reset the Circuit Breaker press the breaker button in until breaker stays in position.

HOUR METER

The hour meter, located on the left side of the operator compartment. This meter records the number of hours the machine has been operated. The hour meter provides a helpful guide for performing routine maintenance tasks, located in the Maintenance Section of this manual.

SEAT ADJUSTMENT

The drivers seat is adjustable to provide the most comfortable position for the operator. The adjustment lever is at the bottom front of the seat. While sitting in the seat, push the lever to the right and pull forward or push back on the seat. Release the lever when the seat is in the proper location.

SPEED CONTROL PEDAL

The control pedal determines the speed of the machine in forward or reverse. Apply pressure to the pedal to increase speed. Decrease pressure to the pedal to slow down. Release pressure from the pedal to stop the machine.

SCRUBBING CONTROL DETAILS/FUNCTIONS

These controls/switches are located to the left of the steering column for easy access and operator identification.

GREEN “ONE-TOUCH” SWITCH

The green “One-Touch” switch operates the entire scrubbing function. When the One-Touch control switch is turned on the following takes place:

1. When the vehicle is in motion, the scrub head lowers to the floor, the main brushes turn on, and the solution control valve is activated. The solution flow will default to the last flow rate chosen but can be varied as required.
2. The main brush down pressure will default to the daily scrub position.
3. The squeegee lowers to the floor and the vacuum fan turns on.
4. If installed the optional side scrub brush will extend, lower, and turn on, and the side brush solution flow will turn on.
5. If installed the chemical metering system will turn on.

SQUEEGEE SWITCH

A separate Squeegee switch is provided. It can be used to prevent the squeegee from operating when the “One-Touch” switch is activated (Allowing for scrubbing only or double scrubbing operation).

SCRUB BRUSHES SWITCH

A separate Scrub Brushes switch is provided. It can be used to prevent the main scrub brushes from operating when the “One-Touch” switch is activated (Allowing for squeegee only operation).

SIDE SCRUB BRUSH SWITCH - OPTION

A separate Side Scrub Brush Switch is provided as an option. It can be used to prevent the side brush from operating when the “One-Touch” switch is activated.

When the vehicle motion is stopped the brushes (including the side brush, if installed) and solution flow will automatically shut off. When the vehicle begins to move the scrub brushes and the solution automatically resume operation.

When the scrubber is driven in reverse the squeegee automatically raises from the floor.

DOWN PRESSURE SWITCH

The Down Pressure is selected using a rotary control knob which provides three pressure settings: Light = 200 lb (90,7 kg); Medium = 300 lb (136,1 kg); and Heavy = 400 lb (181,4 kg). Upon start-up the system responds to the last pressure setting used. The scrubbing pressure can be changed while the scrubber is in operation.

SOLUTION CONTROL KNOB

The solution flow is selected using a three position rotary knob which provides: Off, Low, and High solution flow. The **Low flow setting** is for normal scrubbing, smooth floors, and light dirt. The flow rate is .88 gal/hr (3,33 L/hr), providing 2.0 hours of scrub time. The **High flow setting** is for rough floors and heavy or compacted dirt. The high flow rate is 1.50 gal/hr (5,67 L/hr), providing 1.2 hours of scrub time.

Note: The solution flow starts and stops automatically when the solution flow switch is set in the low or high position. The flow can be manually shut off when sufficient solution is already on the floor. The side brush solution flow starts and stops automatically. The side brush has only one flow rate. The flow rate is factory set, but can be adjusted by turning the slotted screw on the solution solenoid valve located below the frame just behind the side scrub brush.

HOPPER RAISE/LOWER SWITCH

The left switch is the hopper lift raise/lower switch. Pressing and holding the top of the switch raises the hopper. Pressing and holding the bottom of the switch lowers the hopper. The hopper can be stopped at any height by releasing the switch..

HOPPER DOOR SWITCH

The hopper door switch controls the closing of the hopper door. Push the hopper dump door switch up to open the door, and push down to close the door.

HOPPER SAFETY BUTTON (OPTION)

The hopper safety button is for operator safety when lowering the debris hopper. The operator must hold the yellow pushbutton located under the keyswitch. Once the pushbutton is held the operator may lower the hopper using the hopper raise/lower switch. If the pushbutton is released at any point the hopper will stop lowering. The hopper may be lifted without holding the pushbutton as this is for lowering only. This comes standard on all CE machines.

MAIN BROOM SWITCH

A separate Main Broom switch is provided. It can be used to prevent the main broom functions from operating.

SIDE BROOM SWITCH

A separate Side Broom switch is provided. It can be used to prevent the side broom functions from operating.

VACUUM FILTER SWITCH

A separate Vacuum Filter switch is provided. It can be used to prevent the vacuum filter functions from operating.

FILTER SHAKER SWITCH

A separate Filter Shaker switch is provided. It can be used to prevent the filter shaker from operating. The Main Broom must be off in order to use the filter shaker.

BASIC SCRUBBING/FILLING/ EMPTYING INFORMATION

Adjust the machine speed scrub brush pressure and solution flow as required. Use the least amount of brush pressure and solution necessary for the scrubbing application.

When the recovery tank is full the recovery tank indicator light will illuminate and the scrubbing functions will shut off. It is then necessary to drain and clean the recovery tank and refill the solution tank before continuing the scrubbing operation.

CHOOSING THE CORRECT TYPE OF BRUSH (FOR YOUR SCRUBBING APPLICATION)

The main and optional side scrub brushes are available in the following types:

Nylon brush (3313135)

Softer scrub brush for floors coated with light soil.

Midgrit 180 Blue (3332544)

Light abrasive scrub brush for light soil and cleaning floors.

Powergrit 120 AGS Red (3315386)

Mild Abrasive scrub brush for removing light soil.

Powergrit 80 Black (3313125)

Abrasive scrub brush. This scrub brush is impregnated with medium to heavy abrasive grit designed to remove build up like rubber tire marks from heavy traffic areas.

Powergrit 46 HDS Purple (3313127)

Abrasive scrub brush. This scrub brush is impregnated with super heavy abrasive grit designed to remove heavy build up like compacted grease and oil from heavy traffic areas.

Power Drive with Pad Holder (3315494)

Pad Retainer and driver.

Note: Reference Nautilus E Part Catalog for reordering main and side scrub brushes.

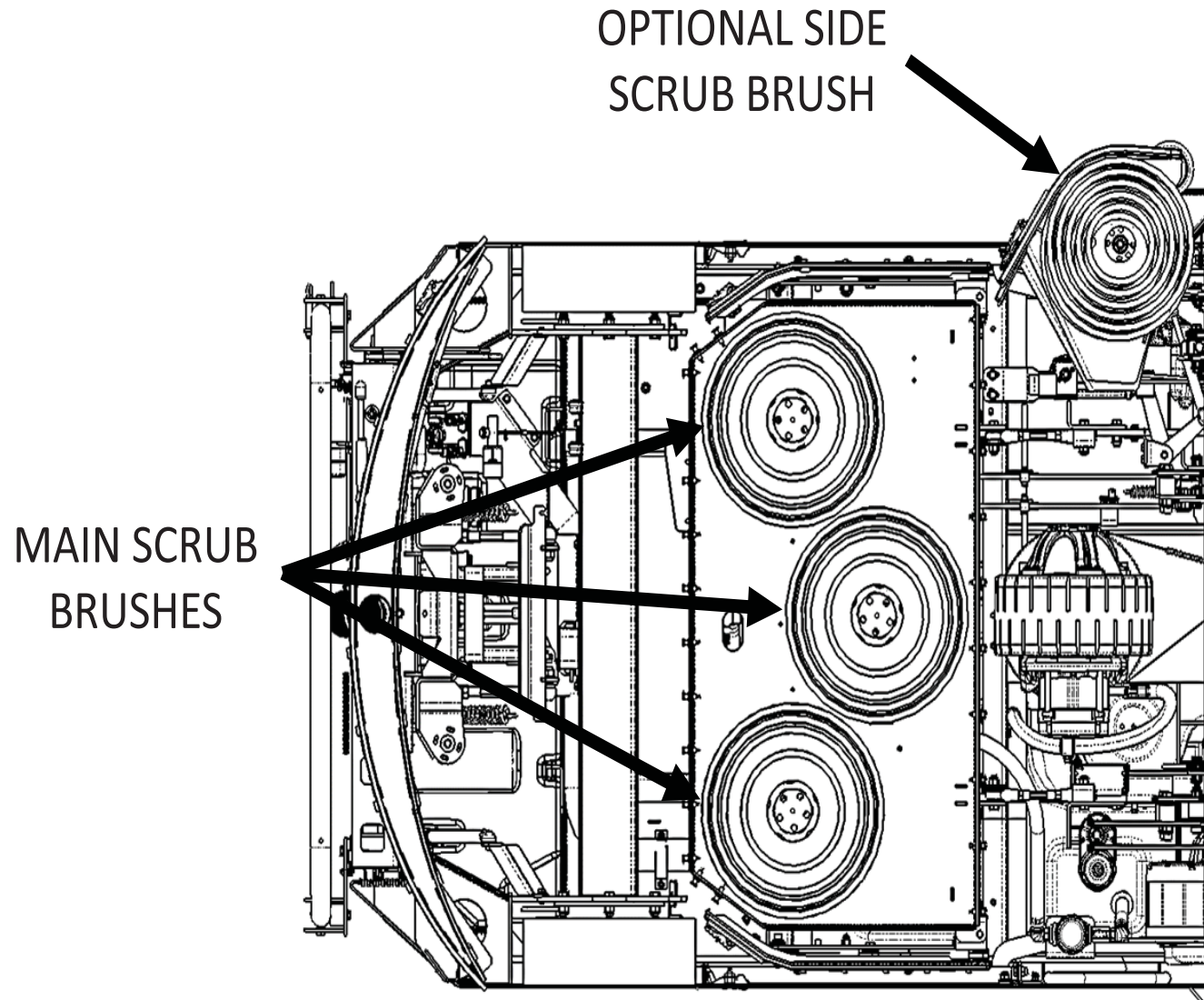

FILLING THE SOLUTION TANK

Open the top cover of the solution tank. Begin filling the solution tank with clean water not to exceed 130°F (55.4°C). When the tank is approximately half full add the appropriate amount of detergent (Do not add detergent in solution tank if you are using the optional chemical metering system for applying detergent). Continue to fill the solution tank with water. The tank is full when the water level reaches the bottom of the metal level indicator (located inside the solution tank).

If the machine is equipped with an optional chemical metering system do not add detergent in the solution tank. Instead, place a container of cleaning solution into the chemical metering box and install the pump suction hose.

Note: Use only recommended cleaning detergents. Machine damage due to improper detergent usage will void the machine warranty.

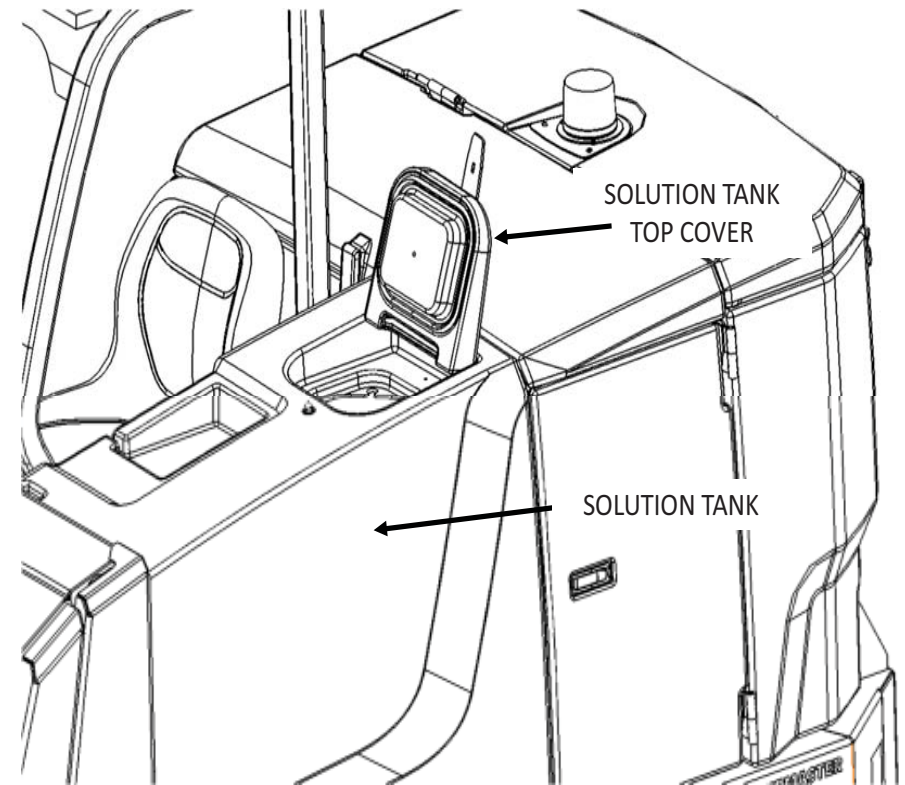

FILLING THE SOLUTION TANK

USING THE AUTO-FILL OPTION:

1. Park the machine on a level surface and set the parking brake.
2. Turn the ignition key to the “on” position, do not start the machine.
3. A. Open the side door.
B. Using the quick connector adapter on the end of a water supply hose connect the supply hose to the auto-fill connector.
C. Turn on the water supply. The water will automatically shut off when the proper level is achieved.
D. When the solution tank is full, turn off the water supply.
E. Disconnect the garden hose and close the side door.
4. Turn the ignition key in the “off” position.

 **WARNING**

Flammable materials can cause an explosion or fire.

Do not use or fill flammable materials in the tank(s).

SWEEPING

- 1 Make sure that the vacuum switch is turned on.
- 2 Actuate the main broom by pushing the Main Broom Switch forward.
- 3 If desired actuate the side broom by pushing the Side Broom Switch forward.
- 4 Drive the machine over the area to be swept.

NORMAL SCRUBBING

This machine is equipped with one button scrubbing. It is not necessary to press all of the scrub function switches each time you begin scrubbing.

1. Start the machine.
2. Ensure that the squeegee and brush switches (to the right of the green one-touch switch) are in the “on” position. Set the brush pressure switch to the lowest setting required for the scrubbing application. Set the solution control knob to the low flow position. (See Fig. 1)
3. Press the top of the green one-touch button to begin scrubbing.

The squeegee will lower, the vacuum fan will start. When the vehicle is driven forward or backward the scrub brushes will lower and start and the solution flow will turn on.

If equipped with the optional side scrub brush: The side scrub brush will extend, lower, and turn on and the solution flow to the side scrub brush will turn on.

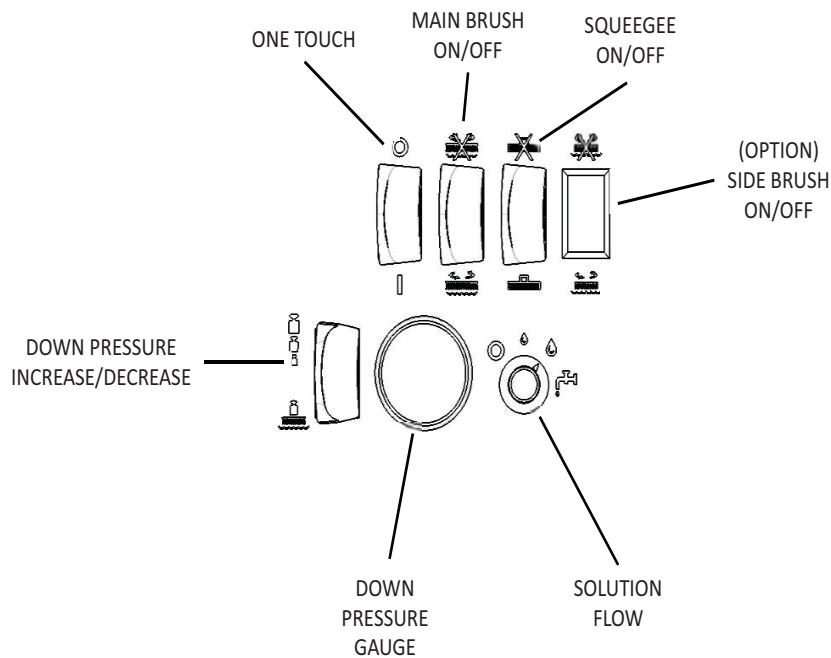

Fig. 1: Control Settings, before “One-Touch” selection

Note: When a new container of detergent has been installed a short amount of time is required for the detergent to mix with the water and reach the floor.

4. Drive the machine forward and scrub as required.
5. Adjust the solution flow as necessary.

The low setting is used for normal scrubbing, smooth floors, and light dirt.

The high setting is for rough floors and heavy or compacted grime.

6. Adjust the scrub brush pressure as required.

There are three brush pressures available.

For normal scrubbing use the lowest brush pressure.

Use the medium or high brush pressure for heavier grime as required.

Note: Higher brush pressures will result in higher brush wear.

DOUBLE SCRUBBING

Double scrubbing is an effective way to remove heavy grime accumulation. This is accomplished by making two passes over the area to be cleaned, the first pass with the squeegee raised.

Note: When double scrubbing it is necessary to manually lock the side squeegee blades (and if equipped, the side brush squeegee blade) in the raised position.

1. Manually lock both side squeegee blades in the raised position. Open the scrub brush door. Lift the side squeegee assembly and rotate the lock arms counter-clockwise until they latch and lock the squeegee blade in the raised position. See Fig. 1.
2. If the machine is equipped with the optional side scrub brush, raise the side brush squeegee blade by removing the squeegee retaining strap, relocating the squeegee blade using the lowest positioning slots (highest squeegee position), then replacing the squeegee retaining strap. See Fig. 2.
3. Start the machine.

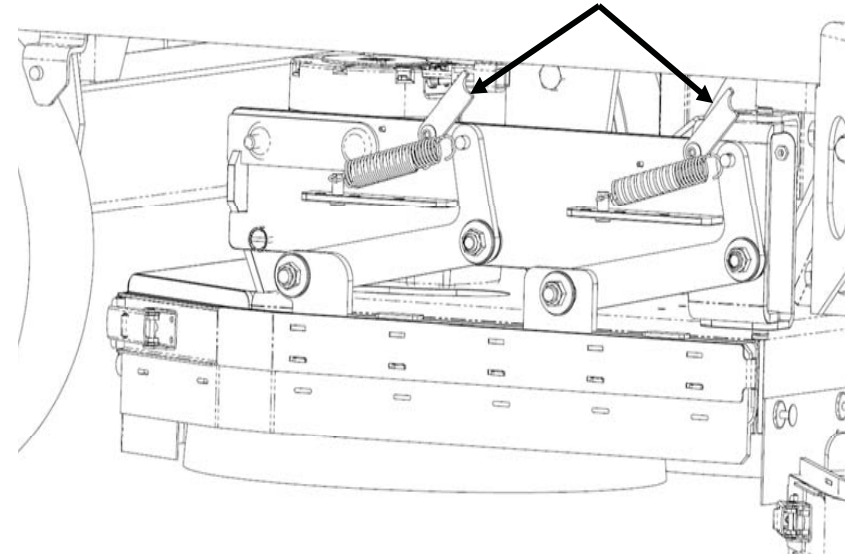

Fig. 1: Shows squeegee assembly retaining arms

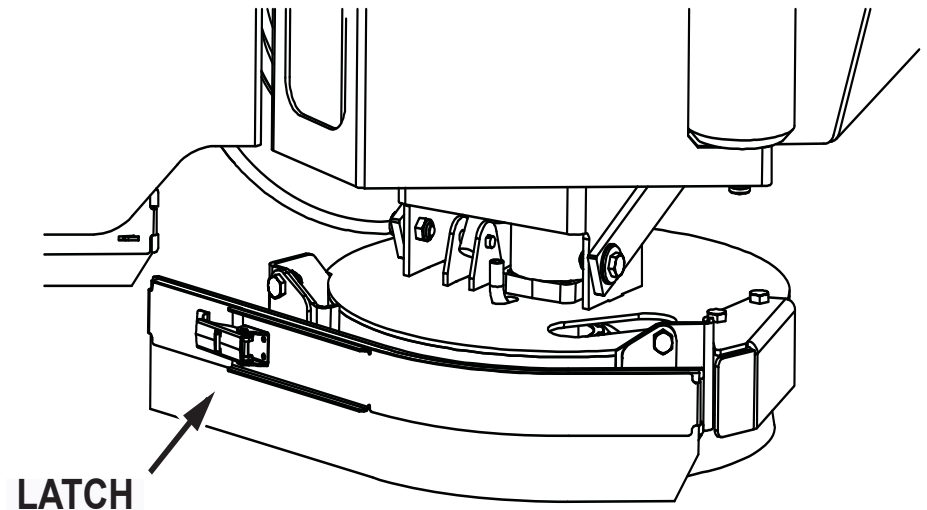

Fig. 2: Optional side scrub brush with squeegee

4. To begin double scrubbing first set the squeegee switch in the “off” position (an illuminated red light on each switch indicates that that function is turned off). This will turn off the vacuum fan and prevent the squeegee from lowering.
5. Press the top of the green one-touch button to begin scrubbing.
6. When double scrubbing use the maximum solution flow setting and a high brush pressure.
7. Make a pass over the area to be scrubbed. This will dispenses solution over the area allowing the detergent to soak on the floor. Let the solution remain on the floor for 5 - 10 minutes, then make a second pass with the squeegee lowered (squeegee switch in the “on” position).

Use caution when double scrubbing in areas where cleaning solution may run under storage racks or damage product.

Note: When finished double scrubbing, unlock the side squeegee blades and reposition the side brush squeegee blade to its original height.

STOP SCRUBBING

1. Press the bottom of the green one touch button to stop scrubbing. The scrub brushes will shut off and raise, and the solution flow will shut off. After a few seconds the squeegee will raise and a few seconds later the vacuum fan will shut off.
2. Continue driving the machine forward until the squeegee raises.
3. When finished set the controls back to the normal scrubbing position.

WATER PICK UP MODE (SQUEEGEE ONLY)

For water pick up or cleaning spills the machine can be operated with the squeegee and vacuum system only.

1. Start the machine.
2. To begin operating with only the squeegee and vacuum system, insure that the squeegee switch is in the “on” position and set the scrub brush switch(s) to the “off” position (an illuminated red light on each switch indicates that that function is turned off). (See Fig. 1).
3. Press the top of the green one-touch button to begin water pick up or cleaning spills.
4. The squeegee will lower and the vacuum fan will turn on.
5. Drive over the spill areas.

! WARNING

**Flammable materials can cause an explosion or fire.
Do not use or fill flammable materials in the tank(s).**

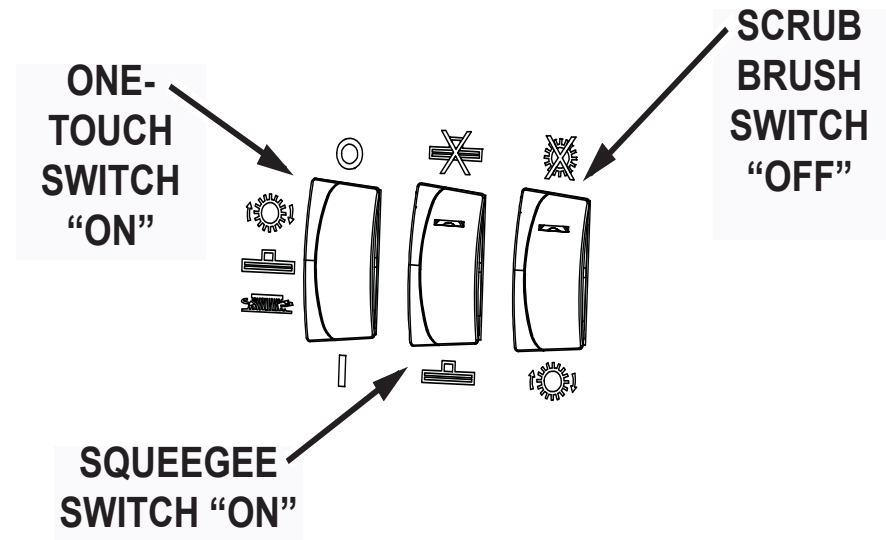

Fig. 1: Control Settings for Water Pick-up Mode

STOP WATER PICK UP

1. Press the bottom of the green one touch button to stop squeegee operation. After a few seconds the squeegee will raise and the vacuum fan will shut off.
2. When finished set the controls back to the normal scrubbing position.

DRAINING/CLEANING THE RECOVERY TANK

Note: The recovery tank must be emptied and cleaned daily.

When the recovery tank is full or you are finished scrubbing the recovery tank must be drained and cleaned.

1. Drive the machine to an appropriate dump site. Shut off the machine, and set the parking brake.
2. Open the demister. (See Fig. 1)
3. Remove the plug from the end of the recovery hose.
4. Place the end of the recovery tank drain hose on the floor near a floor drain. (See Fig. 1)
5. When the tank is fully drained rinse out the tank with clean water.

Note: Do not use steam to clean the tank as this will damage the tank.

6. Rinse the float sensor, inside the Recovery Tank.
7. When finished cleaning and draining the tank, twist the plug back into the end of the recovery hose.
8. Reinstall the drain hose onto the back of the recovery tank.
9. Close the recovery tank top covers.
10. Rinse off the exterior of the tanks as necessary.

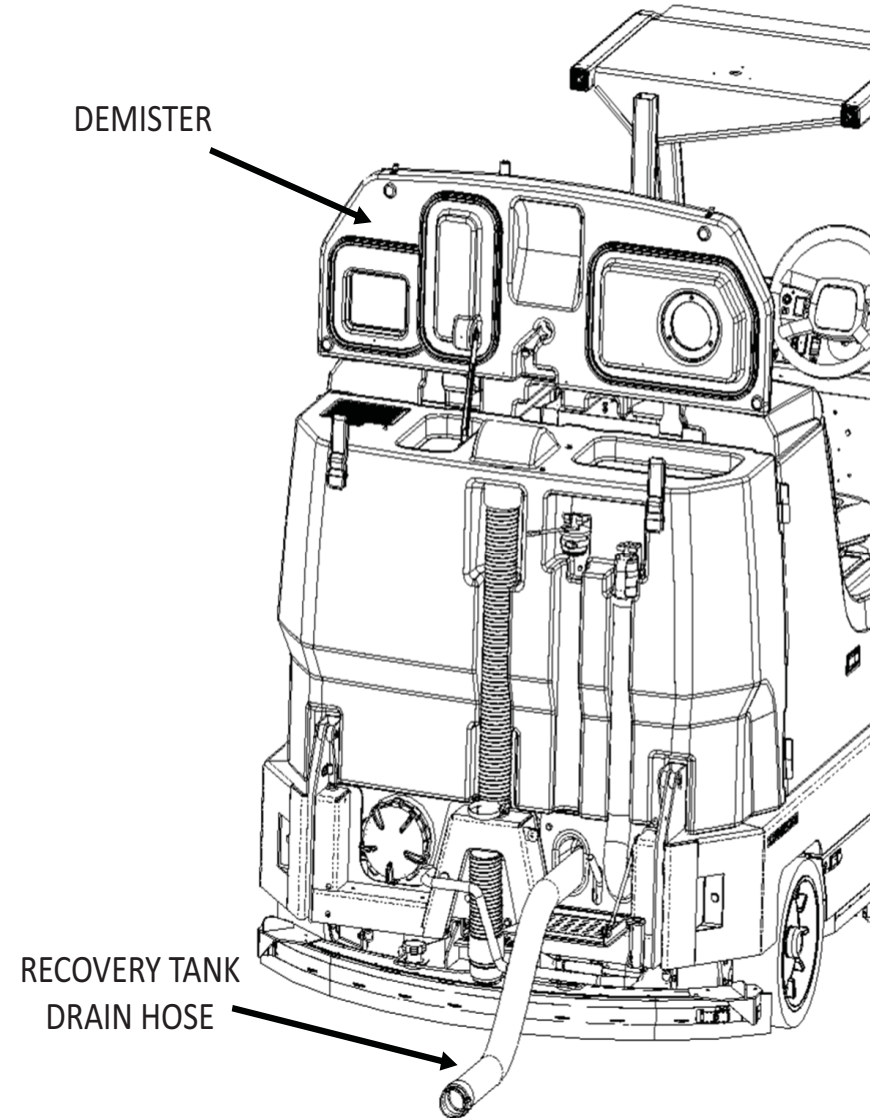

Fig. 1: Draining the Recovery Tank

RAISING THE BUMPER

Note: Raising the bumper is necessary to more easily access the squeegee..

1. Shut off the machine, and set the parking brake.
2. Pull the rear step down into position.
3. Release the rear bumper latch located under the right side of the rear frame while lifting up on the bumper lever arm. (See Fig. 1)
4. Swing the orange bumper lever arm out from under the rear bumper. (See Fig. 1)
5. Raise the bumper up until the safety arm locks into place.

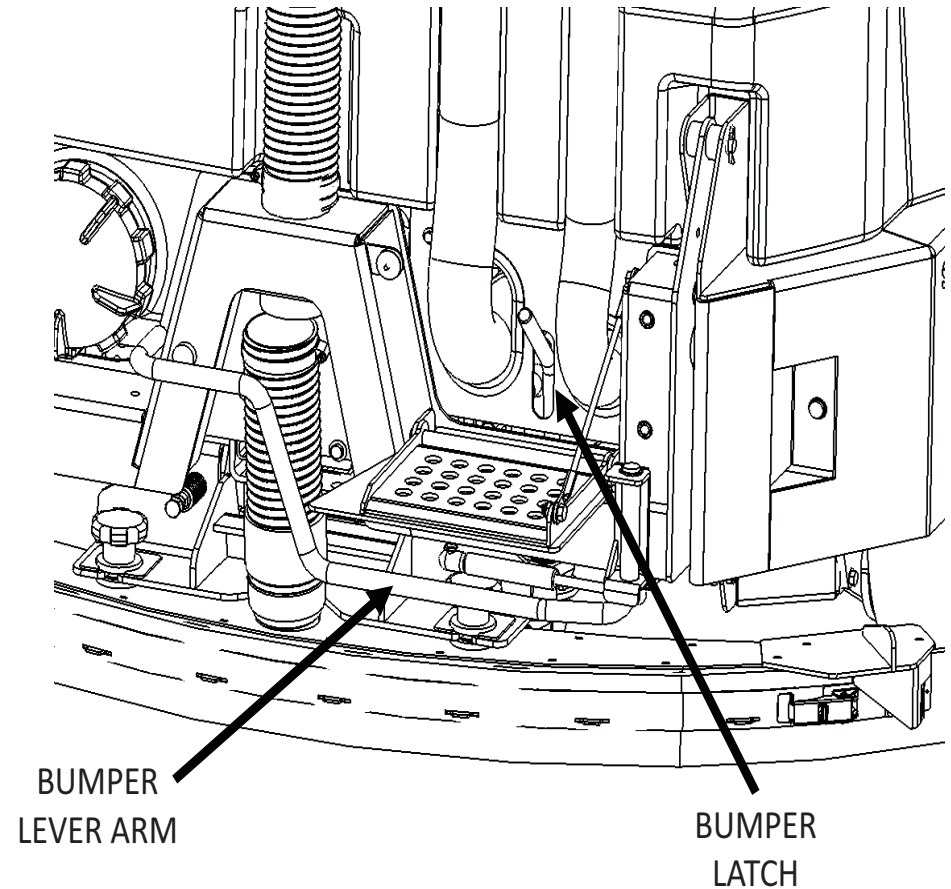

Fig. 1

EMPTYING/CLEANING THE DEBRIS HOPPER

Note: The debris hopper must be emptied and cleaned daily.

1. Drive the machine to an appropriate dump site or debris dumpster.
2. Press and hold the top of the hopper raise/lower switch (left switch). Release the switch when the hopper is at the desired height.
3. Drive the machine to the debris dumpster.
4. Press the top of the hopper dump door switch (right switch). This will open the hopper dump door and empty the contents of the hopper.
5. When the hopper has emptied slowly back the machine away from the debris site or debris dumpster.
6. Press and hold the bottom of hopper raise/lower switch (left switch) until the hopper is completely lowered..

Note: It is necessary to operate a switch to close/open the hopper door.

FOR SAFETY: Do not raise hopper when the machine is on an incline. Make sure adequate clearance is available before raising hopper.

FOR SAFETY: Use care when moving the machine with the hopper raised.

Note: A minimum ceiling height of 7'-3" (2540mm) is required to fully raise the hopper

Note: The hopper door will remain open.

HOPPER FILTER REMOVAL

1. Release the latch on the hopper cover and raise the cover.
2. Disconnect the wire harness connector leading to the filter shaker motor.
3. Unscrew the four knobs (each having one conical washer and an isolator) securing the filter retainer bars to the hopper.
4. Remove the shaker motor assembly and filter retainer bars.
5. Lift out the panel filter.

FILTER CLEANING

The dust control filter is a Merv 13 ULPA element filter. It may be vacuumed, blown out with compressed air, tapped against the floor or washed with soap and water.

1. If blown out with compressed air, use 100 psi (689 kPa) or less.

2. If washed with soap and water, use 40 psi (275 kPa) water pressure or less.

NOTE: Make sure the filter is thoroughly dried while standing on its side before installing in the hopper.

***** Do not install or use a wet filter.**

FILTER REPLACEMENT

1. Insert the panel filter.
2. Install the shaker motor assembly.
3. Install and tighten the four knobs, washers, and isolators.
4. Reconnect the wire harness connector to the filter shaker motor.
5. Close the hopper cover and secure the latch.

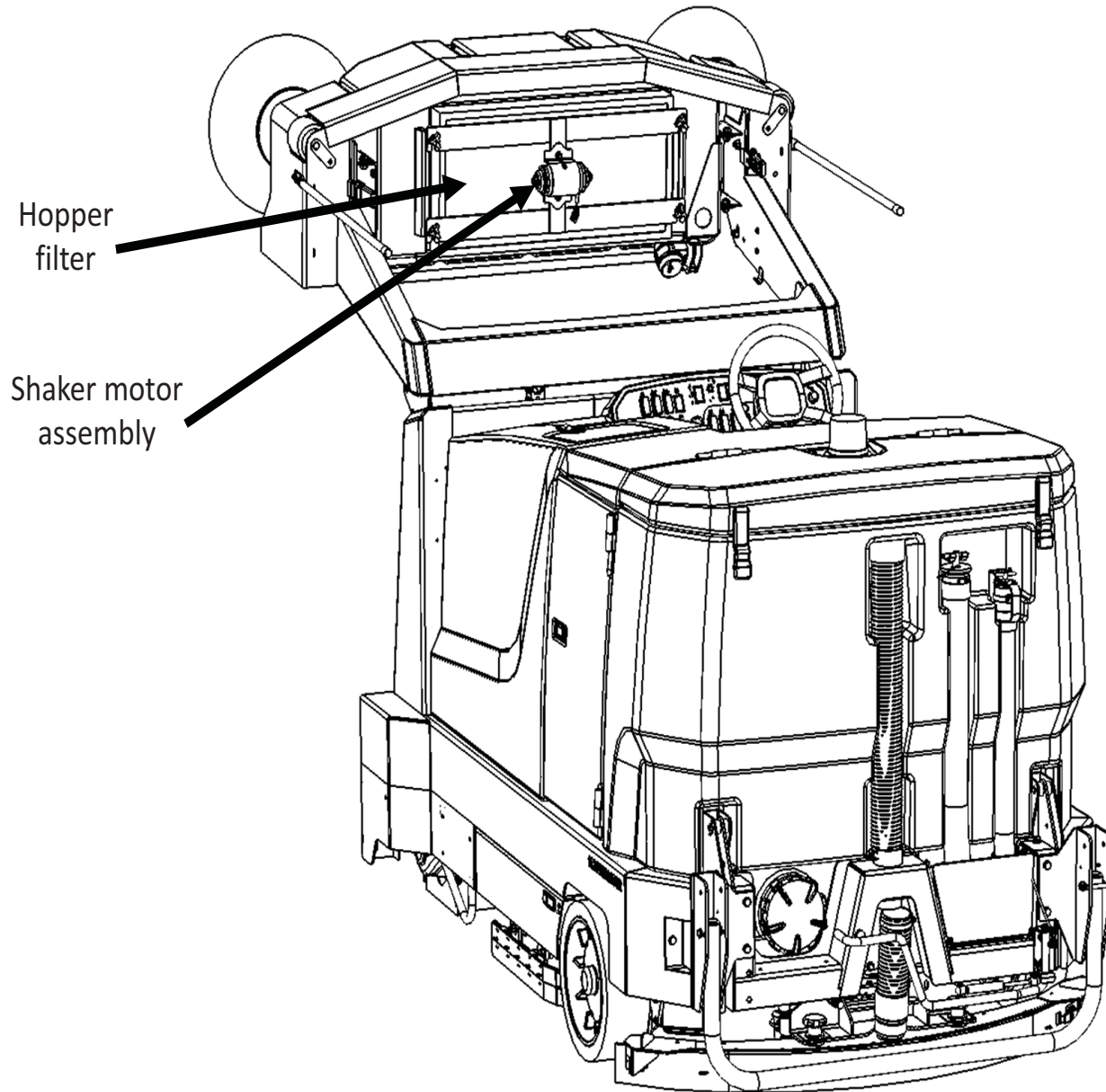

DRAINING THE SOLUTION TANK

1. Drive the machine to an appropriate dump site. Shut off the machine and set the parking brake.
2. Open the solution tank top cover.
3. Grab the end of the solution tank drain hose and lower slowly to the floor near floor drain. (See Fig. 1)
4. Loosen and remove the cap. (See Fig. 1)

Note: Depending on the level of liquid in the solution tank the liquid may exit under pressure.

5. After tank has fully drained reinstall the cap.
6. Reinstall the drain hose onto the back of the recovery tank.
7. Close the solution tank top cover.

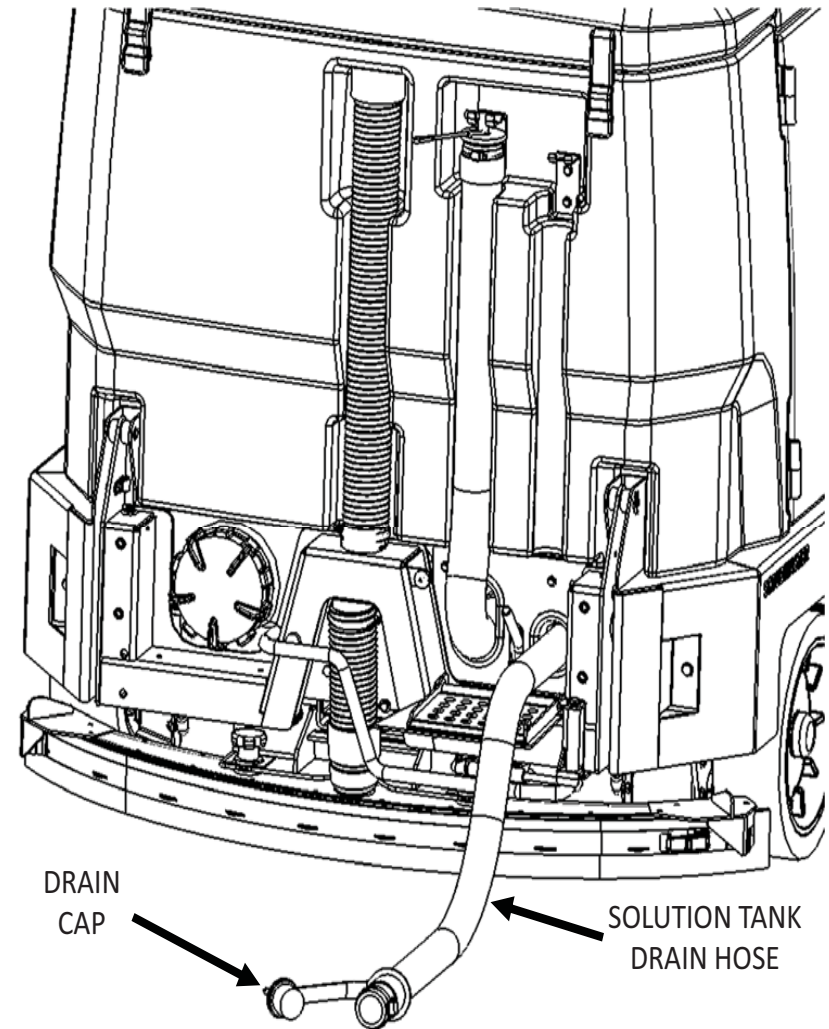

Fig. 1: Draining the Solution Tank

OPERATING PROCEDURES

PRE-OPERATION CHECKS

Prior to starting the machine, check the following:

1. Confirm the battery is charged.
2. Hydraulic fluid level is within the operating range -- indicated fluid level within the sight gauge.
3. Brakes, steering, and directional controls.
4. Signs of fluid leaks on and under the machine.
5. Condition of scrubbing brushes. Remove any strings and debris wrapped around them.

Fluid levels should be within the correct amounts to operate the machine.

Brakes, steering and directional controls should be functioning properly.

Hoses, lines and tanks should be free of damage and leaks.

STARTING

WARNING

Before starting the machine, sit in the operator's seat and make sure the parking brake is engaged.

1. Engage the parking brake.
2. Turn the ignition key to the start position (clockwise).

DRIVING

The direction control pedal moves the machine forward and backward. To move the machine forward or backward, first release the parking brake.

- To move Forward: Push the directional switch forward. Use the control pedal to control the speed.
- To move Backwards: Push the directional switch down. Use the control pedal to control the speed.

SLOWING AND STOPPING

Allow the directional control pedal to move into neutral. Step on the brake pedal.

INCLINES OR SLIPPERY SURFACES

Always travel slowly when operating on inclines or slippery surfaces.

WARNING

Do not travel across or turn on inclines, to maintain stability of the machine.

Always travel straight up or down on inclines.

STOP THE MACHINE

1. Stop scrubbing and drive the machine forward until the rear squeegee raises.
2. Stop the vehicle using the foot brake.
3. Turn off the ignition key switch to the off position.
4. Remove the key.
5. Set the parking brake.

TRANSPORTING THE MACHINE

USING A TRAILER OR TRANSPORT VEHICLE

1. Position the machine on the transport vehicle or trailer and apply the parking brake.
2. Tie the machine down using the tie down bars on both sides of the front corners and behind both rear wheels.

Note: Attach the tie downs to the tie down bars only.

CAUTION

The tow control valve must be turned 90 degrees from the operating position.

Not turning the tow control valve will cause damage to the pump.

ATTENTION!

Do not tow or push the machine a distance of more than 0.5 mi (0,8 km) or faster than 1 mph (1,6 km/hr). Exceeding these restrictions may cause damage. If towing will exceed the above restrictions, the rear wheel must be raised or supported by a dolly.

OPTIONS

CHEMICAL METERING

The chemical metering option is used to meter the optimum amount of detergent onto the floor while scrubbing.

1. Place a full container of detergent (appropriate for the application) into the detergent container rack located on the top of the solution tank. (See Fig. 1)

Note: Use only recommended cleaning detergents. Machine damage due to improper detergent usage will void the machine warranty.

2. Remove the detergent container cap and replace it with the suction hose cap.
3. Set the chemical metering flow rate. (See Fig. 2)
There are chemical flow rates available. For normal scrubbing use the lowest chemical flow rate. For heavier scrubbing use the medium or high chemical flow rate.
4. Turn on the chemical metering switch. (See Fig. 2)
5. When scrubbing, the correct amount of detergent will automatically be added to the solution delivery system.

Note: During the first use after a new container of detergent is installed it may take some additional time for the detergent to reach the floor.

AUTO-FILL

The auto-fill option allows for unattended filling of the solution tank.

The system automatically shuts off the flow of water to the solution tank when the tank is full. See the section on “filling the solution tank” for more details on this option.

OPERATOR SEAT SENSOR (CE)

The Operator Seat Sensor safety option senses when the operator of the vehicle is sitting in the driver seat. This sensor will automatically turn off the running machine, if the operator leaves the seat for longer than 3 seconds. If the parking brake is engaged it will bypass the seat contact switch so that the machine will continue to run so the mechanic can work on it.

This safety option is standard on Nautilus E CE machines and available for other Nautilus E machines.

SPRAY AND VACUUM WAND

The spray wand option is used to clean areas that are otherwise inaccessible.

1. Park the machine close to the area to be cleaned.
2. Lower the squeegee and shut off the machine.
3. Set the parking brake.
4. Remove the hose from the top of the rear squeegee.
5. Remove the spray wand tubes from the retainer clips and assemble the wand.
6. Remove the vacuum hose from the hose rack and attach the small end of the hose to the upper end of the wand and the large end of the hose to the machine squeegee hose.
7. Attach the wand solution hose to the quick disconnect fitting on the upper end of the wand and to the quick disconnect fitting located on the rear bumper of the machine between the tank drain hoses. (See Fig. 1)
8. Start the machine.
9. Lower the squeegee to turn on the vacuum system.
10. Turn the Vac & Spray Wand switch located on the instrument panel to the “on” position. (See Fig. 2)

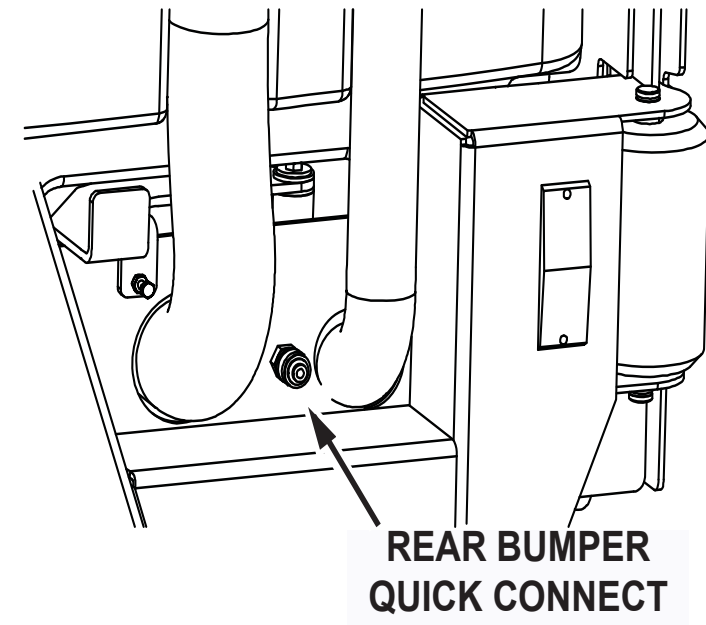

Fig. 1: Spray Wand Quick Disconnect

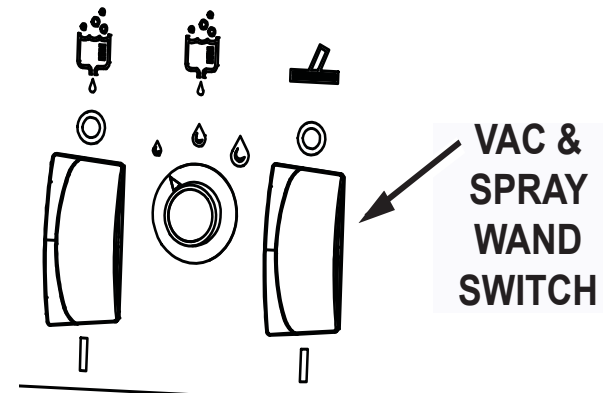

Fig. 2: Vacuum and Spray Wand Switch

11. Apply solution to the area to be cleaned by activating the solution valve lever on the upper end of the wand.
12. Use the brush bar on the lower end of the wand to scrub the area to be cleaned.
13. Vacuum the floor using the squeegee on the lower end of the wand.

! WARNING

**Flammable materials can cause an explosion or fire.
Do not vacuum/pick up flammable materials.**

When wand cleaning is complete:

14. Turn off the Vac & Spray Wand switch.
15. Shut off the machine.
16. Remove the wand vacuum hose from the wand and the machine squeegee.
17. Re-connect the machine squeegee hose onto the machine squeegee.
18. Put the wand and wand vacuum hose in the wand clips and hose rack.

SUSPENSION SEAT

The suspension seat comes equipped with:

1. Hand lever for seat adjustment.

Adjusts the seat lengthwise. Pull lever to release. Let the lever catch after adjustment.



1

2. Rotary knob for lumbar adjustment.

Turn knob to the left for more support. Turn the knob to the right for less support.



2

3. Rotary knob for backrest adjustment.

Turn knob to the left to incline the seat backward. Turn the knob to the right to bring the seat back up.



3

4. Rotary knob for cushion adjustment.

Turn knob to the right for firmer cushion support. Turn knob to the left for softer cushion support.



4

5. Armrest adjustment screw.

Adjusts the inclination of the armrest.



5

SIDE SCRUB BRUSH

Turn on the side brush using the side brush switch on the console. Turn off the side brush using the same switch.

The side brush cannot operate independently from the main sweep brushes. The main brushes also come on when the side brush switch is pushed.

SEAT BELTS

Seat belts are offered as an option on both the standard seat, and the suspension seat.

LIGHTS

Safety lights are offered in blue, amber, or red. The lights can be mounted on the solution tank, or the Overhead Guard. The lights can flash, rotate, or strobe.

The lights will come on automatically when the machine is turned on.

PREVENTATIVE MAINTENANCE

Introduction

Regular maintenance on your sweeper results in better cleaning, faster cleaning and a prolonged service life for the equipment and components. This section contains the following information to help you give your sweeper the maintenance attention it requires:

- A Scheduled Maintenance Chart
- Preventative Maintenance Instructions for Required Scheduled Maintenance Tasks

Because it is extremely important to your safety, you will see the following WARNING repeated throughout this section:

WARNING

Never attempt to perform any service on the equipment or components until:

- 1) The Vehicle is Parked on a LEVEL GROUND.**
- 2) The machine is OFF.**
- 3) The Parking Brake is LOCKED.**
- 4) The Wheels are CHOCKED.**

FREQUENCY (IN HOURS)	SERVICE (BY MAINTENANCE AREA)
50	Scrub Head Skirts (disk)- Check for damage and wear
	Sweeping Skirts - Check for damage and wear
	Sweeping Side Brush(es) - Check brush pattern
	<i>Solution Supply Filter - Check screen and clean</i>
	Live Wand Vacuum Seals (Option) - Check for damage and wear
100	Battery Watering System (Option) - Check hoses and connections for damage and wear
	Hopper Seals - Check for damage and wear
	Hopper - Clean hopper and dust filter
200	Brakes - Check adjustments
	Battery Terminals and Cables - Check and clean
	Cylindrical Brush Drive Belts - Check for damage and wear
	Sweeping Brush Drive Belts - Check for damage and wear
	Drive Wheel pivot - lubricate
	Steering Chain - lubricate
	Steering Gear Chain -lubricate
	Hopper Chains - lubricate
	Hopper Lift Arm Pivots - lubricate

FREQUENCY (IN HOURS)	SERVICE (BY MAINTENANCE AREA)
500	Scrub Vacuum Fan Motor(s) - Check motor brushes
	Tires - Check for damage and wear
	Hopper Chains - Check tension
800	Hydraulic Hoses - Check for damage and wear
	Drive Wheel Motor - replace oil
1000	Sweeping Side Brush Motors - Check motor brushes (check every 100 hours after initial 1000 hour check)
	High Pressure Washer Motor - Check motor brushes (check every 100 hours after initial 1000 hour check)
2400	Hydraulic Reservoir - Change hydraulic fluid

ELECTRICAL SYSTEM

Battery Cleaning

1. Combine baking soda and water in a strong solution.
2. Brush the solution over the battery top, including terminals and cable clamps. Make sure the solution does not enter the battery.
3. Using a wire brush, clean the terminal posts and cable clamps.
4. Apply a thin coating of petroleum jelly to the terminals and cable clamps.

Battery Replacement

 **CAUTION**

Remove the negative battery cable before you remove the positive battery cable. This is done to prevent accidental electrical shorting which can result in personal injury.

1. Disconnect the negative (-) cable and then the positive (+) cable.
2. Remove the battery.
3. Install the new battery.
4. Connect the positive (+) battery cable first, then the negative (-) cable.

Circuit Breaker

If the circuit breaker trips, it can be reset by pressing the reset button in the center of the breaker. (The circuit breakers are located below the left panel of the steering wheel). Press the reset button to reset the circuit breaker.

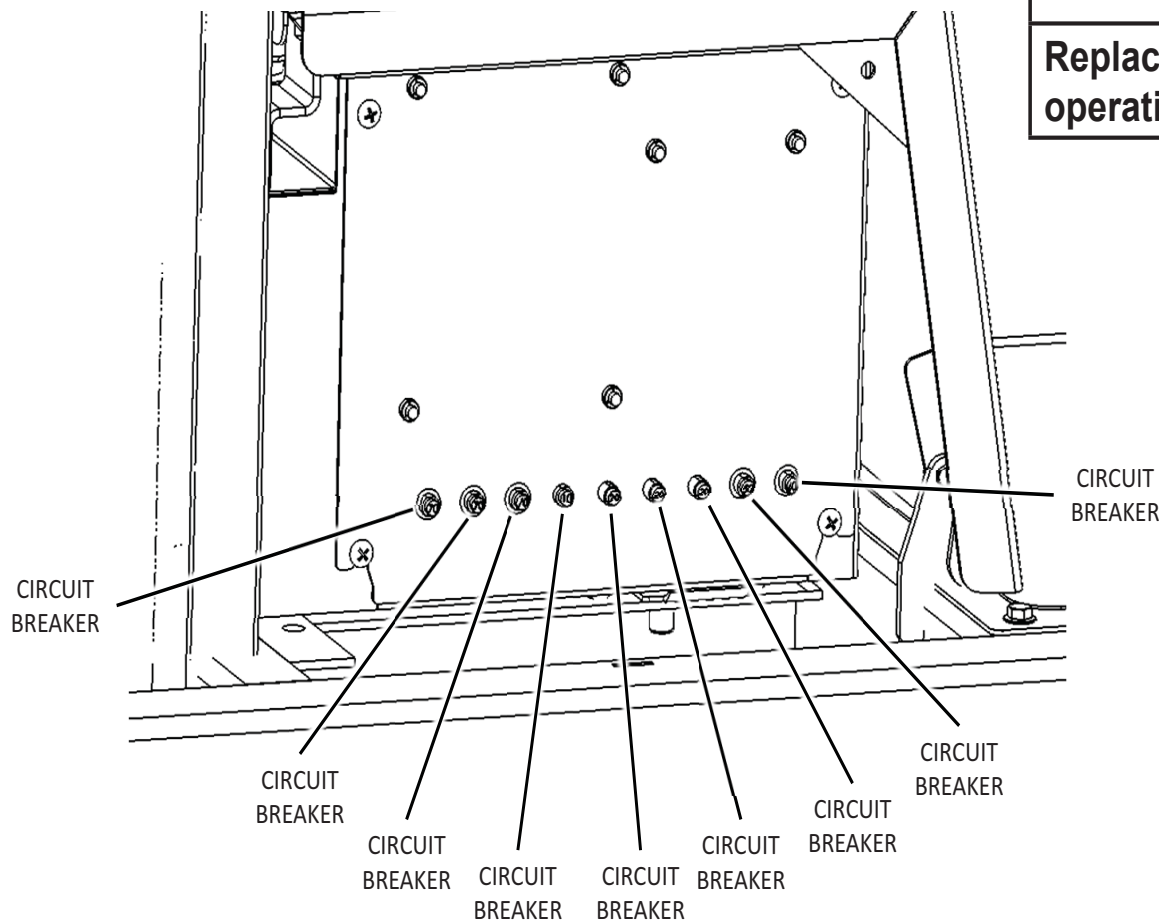

⚠ WARNING

Never attempt to perform any service on the equipment or components until the parking brake is **LOCKED**, and the wheels are **CHOCKED**.

⚠ WARNING

Replace any defective safety components before operation the sweeper.

LUBRICATION POINTS

Steering Fork Bearings

The steering fork bearings are located above the front wheel.

Rear Wheel Bearings

Repack the rear wheel bearings every 400 hours of operation using Lubriplate EMB grease and replace damaged seals.

Squeegee Caster Bearings

Lubricate the squeegee caster bearings every 100 hours using Lubriplate EMB grease.

Scrub Head Lift Arm Bearings

Lubricate the hopper lift bearings every 500 hours with light oil.

Drive Wheel Pivot

Lubricate the drive wheel pivot every 200 hours with light oil.

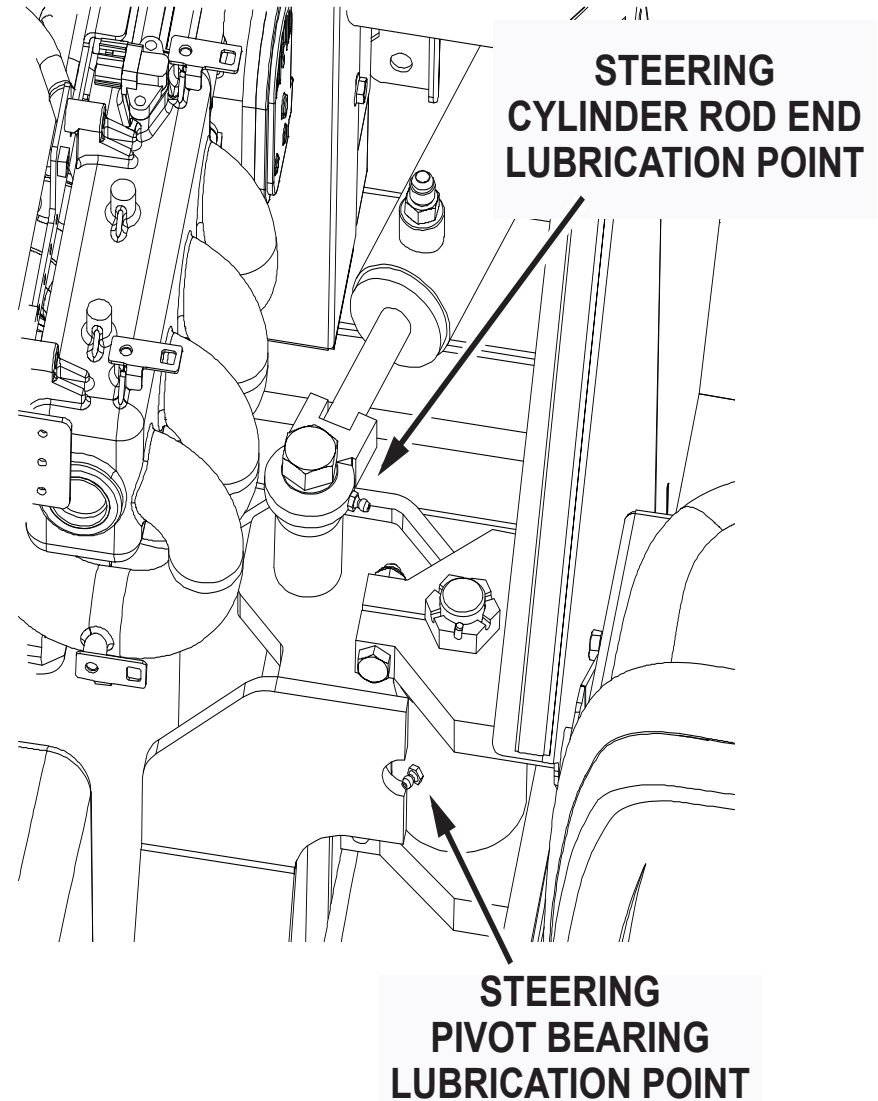

Fig. 1: Lubrication Points

Bumper and Hopper Lift Arm Pivot Bearings

Lubricate every 200 hours using Lubriplate EBM grease.

LATCHES & HINGES

Lubricate the cover hinges every 200 hours of operation with light machine oil. Lubricate the following:

- Front cover, hinges and latches
- Side doors, hinges and latches
- Top cover, hinges and latches
- Scrub head doors

The scrub head lift arm bearings are located on both sides of the machine above the scrub head. These bearings can be accessed when the scrub head is in the lowered position.

Lubricate the steering fork bearings every 100 hours using Lubriplate EMB grease.

Hopper Lift Arm Mounts

The hopper lift arm mounts must be lubricated every 500 hours with lithium grease, There are two lubrication points on each mount.

1. Park the machine on a level surface.
2. Raise the hopper and engage the safety arm
3. Shut off the engine and engage the parking brake.

Nautilus E Rider Scrubber/Sweeper #988768UM-D Rev. B 11/20

4. Locate and grease the hopper lift arm lubrication points.

WARNING

Do not rely upon the hydraulic cylinders to keep the hopper raised. Always engage the safety arm before servicing the hopper.

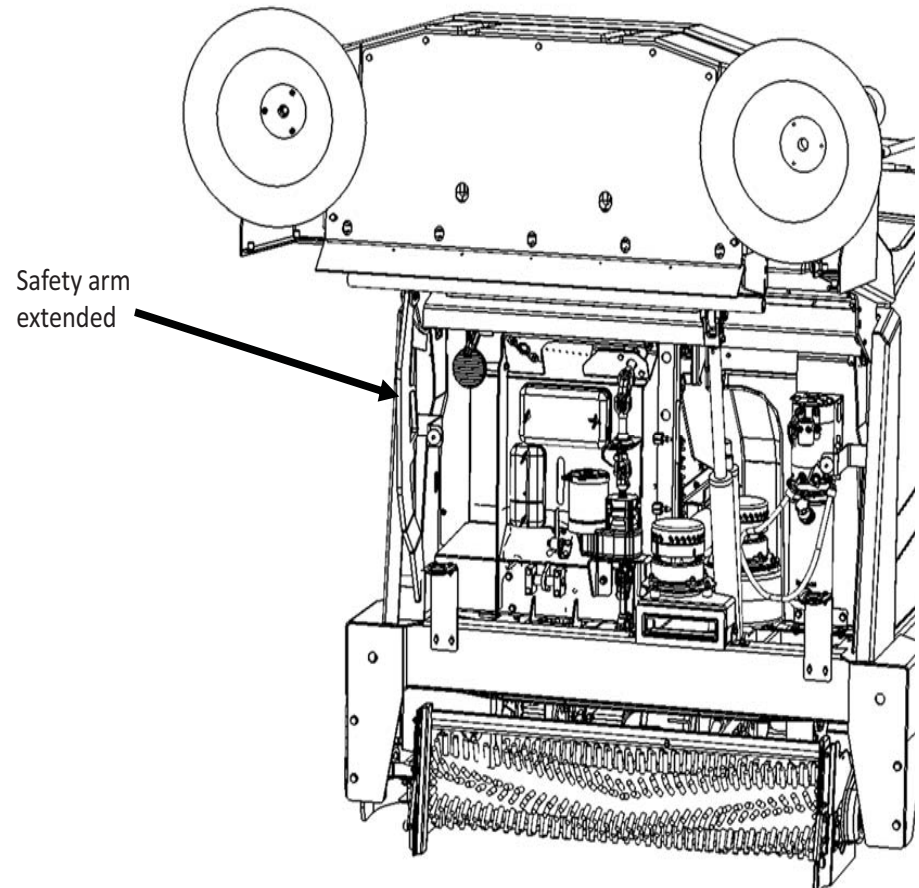

**HOPPER LIFT ARM MOUNT
LUBRICATION POINT**

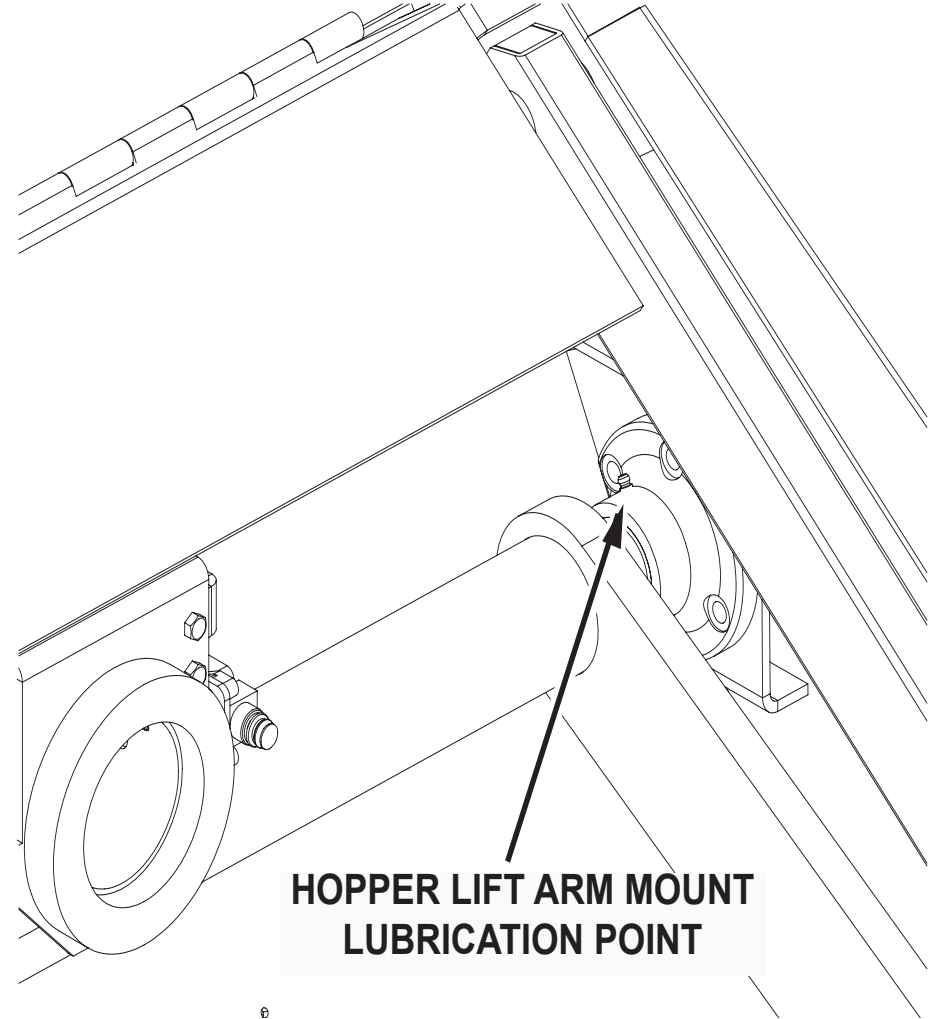
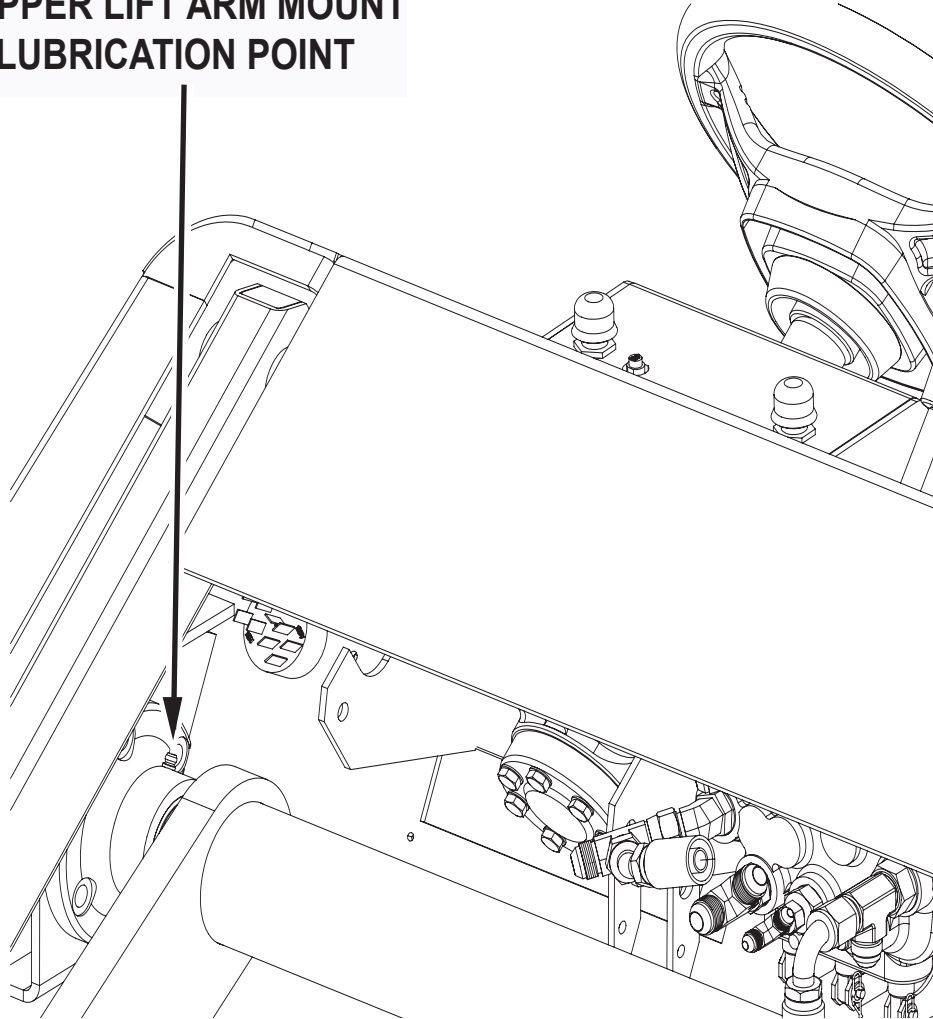

GROUNDING CHAIN

A grounding chain prevents the buildup of static electricity in the machine. The grounding chain is attached to the back of the frame behind the left rear tire. Replace the grounding chain if it is damaged or no longer touches the floor.

HYDRAULIC SYSTEM

Hydraulic Fluid Reservoir

The hydraulic fluid reservoir is located in the front of the machine on the left side. (See Fig. 1)

Note: Only fill tank when arms are in downposition.

The reservoir has a sight gauge to quickly view if there is a sufficient amount hydraulic oil in the reservoir tank to run the machine. Check daily and add hydraulic oil as needed.

 **CAUTION**

**DO NOT OVERFILL HYDRAULIC RESEVOIR TANK!
DO NOT USE TRANSMISSION FLUID!**

 **CAUTION**

**Minuteman International, Inc. recommends using:
Dextron Automatic Transmission Fluid**

Changing the Hydraulic Fluid

1. Turn off the machine and engage the parking brake.
2. Place a drain pan under the reservoir tank.
3. Remove the drain plug, unscrew with 5/16 in (8 mm) hex head wrench, located on the bottom of the reservoir and allow the fluid to drain.
4. Discard the fluid in an approved manner, then replace and retighten the drain plug.
5. Remove the fill cap located on top of the reservoir and fill the reservoir with the recommended hydraulic fluid: (Mobil DTE 10 Excel 32 Hydraulic Oil or equivalent).

Note: A minimum of 7 gal - 8 gal (26.5 L - 30.3 L) of hydraulic oil is needed to fill the reservoir tank to the correct amount. The maximum volume capacity of the hydraulic reservoir tank is 9.9 gal (37.5 L). Do not fill to this maximum capacity!

6. Visually see if the hydraulic oil level is at or above the sight gauge. Confirm the hydraulic oil level is within the high and low markers on the dip stick. Add or remove hydraulic fluid as needed. (Reference fill line)
7. Verify the fill cap is hand tight to prevent leakage.
8. Start the machine, shut it off, then check for leakage.

SCRUBBING COMPONENTS

Scrub Brush Replacement

WARNING

Never attempt to perform any service on the equipment or components until the machine is OFF, the parking brake is LOCKED, and the wheels are CHOCKED.

This machine is equipped with three scrub brushes. These brushes scrub the floor, and also sweep debris into the debris hopper. These brushes should be checked daily for wear and damage, as well as entangled string, plastic, or wire. The Power-Drive scrub brush features a quick release mechanism which enables the operator to remove the brush in seconds.

Note: Brushes should be replaced when the bristles are less than 1/2" (12.77 mm) long.

- 1 Set the parking brake. (See Fig. 1)
- 2 Raise the scrubhead.

- 3 Turn the scrub brush by hand until the brush locking spring is accessible.
- 4 Squeeze the ends of the locking spring using a downward motion and the brush will release from the driver.
- 5 Install the new brush by positioning the socket in the brush with the driver on the scrub motor.
- 6 Lift the brush until the brush retainer springs over the driver locking it into position.
- 7 Check to make sure that the brush is properly engaged.

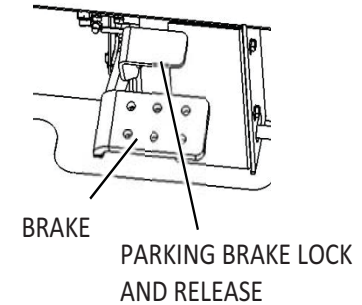
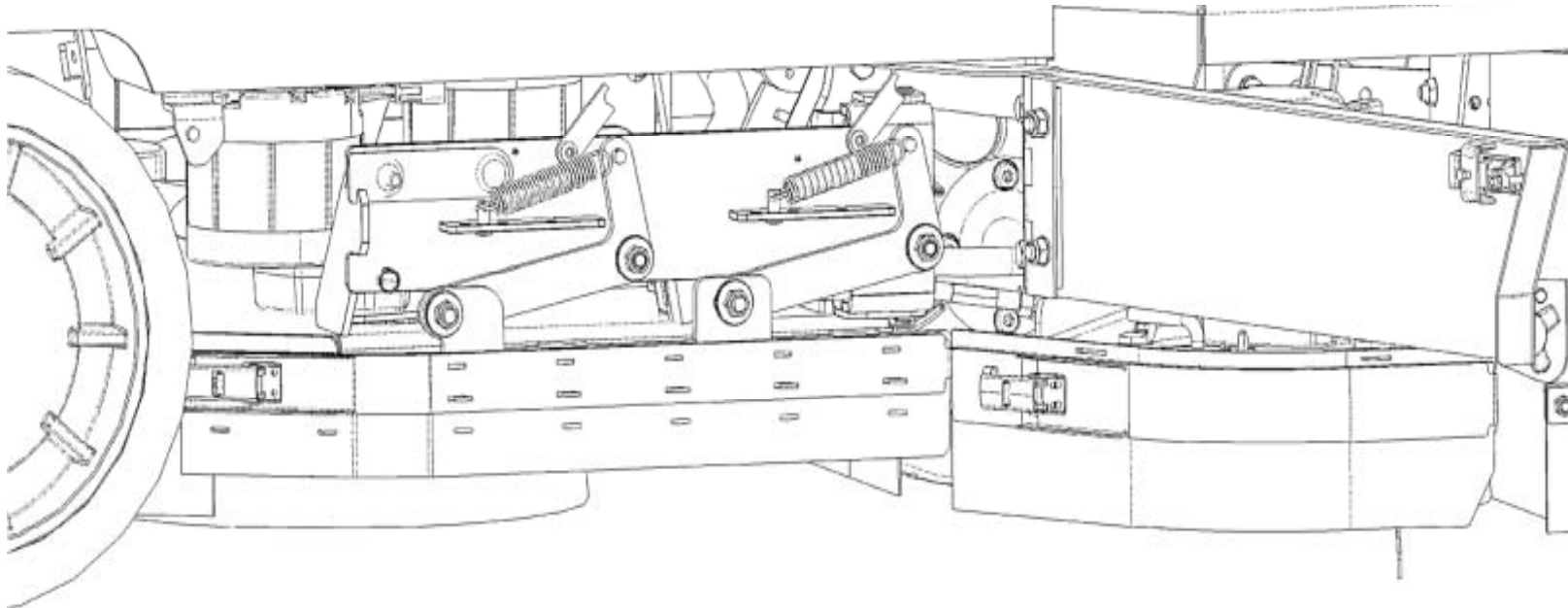

Fig. 1: Set the Praking Brake



Checking the Scrub Brush Pattern

For the best results perform the scrub brush pattern tests on a smooth even floor.

Note: Chalk or chalk powder applied to the floor will help to show the brush pattern. If chalk is not available allow the brushes to turn on the floor for 1 or 2 minutes. A polished brush pattern will be visible on the floor.

1. Raise the scrub deck.
2. Position the scrub deck over the chalked area.
3. Set the parking brake.

For Safety: Before leaving machine, turn off the machine, set the parking brake, and remove the key.

4. Lower the scrub head for 10-15 seconds. Do not allow the machine to move forward or backward.
5. Raise the scrub deck.
6. Release the parking brake and drive the machine away from the chalked area.
7. Check the width and shape of the brush patterns on the floor. (See Fig. 7)

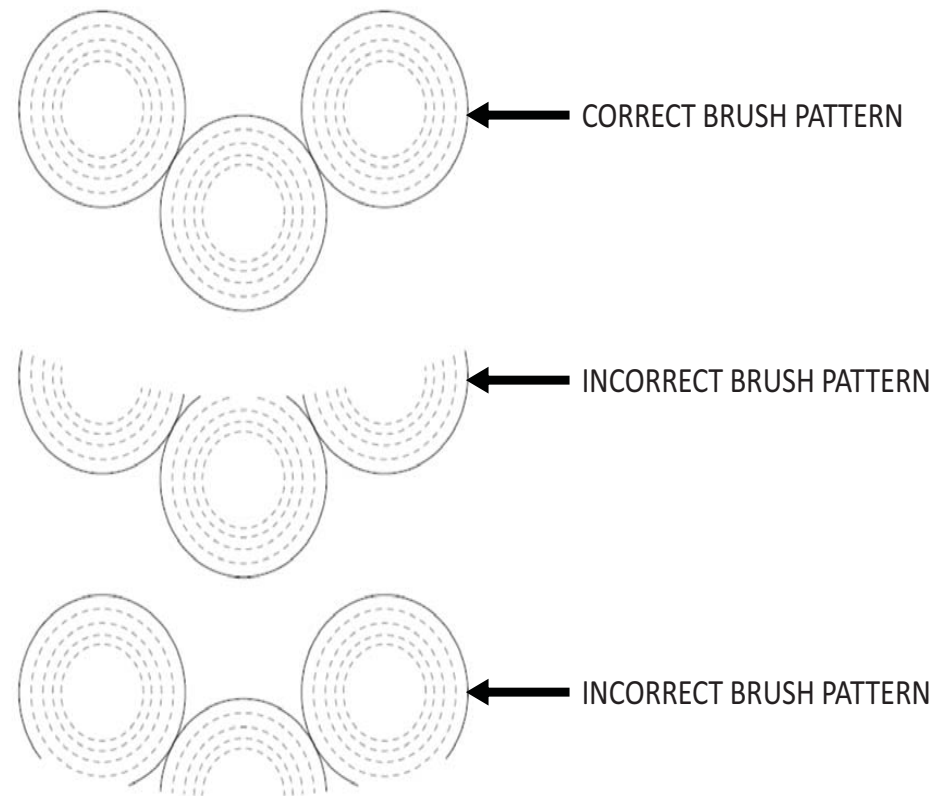

Fig. 7: Scrub Brush pattern

Adjusting the Scrub Brush Pattern

The scrub brush pattern leveling rods are located in the front of the scrub deck, and be accessed from under the machine.

1. Park the machine on a level surface.
2. Set the parking brake.
3. From under the machine, adjust the leveling rods as necessary (See Fig. 1).
4. Check the scrub brush pattern again and readjust if necessary.

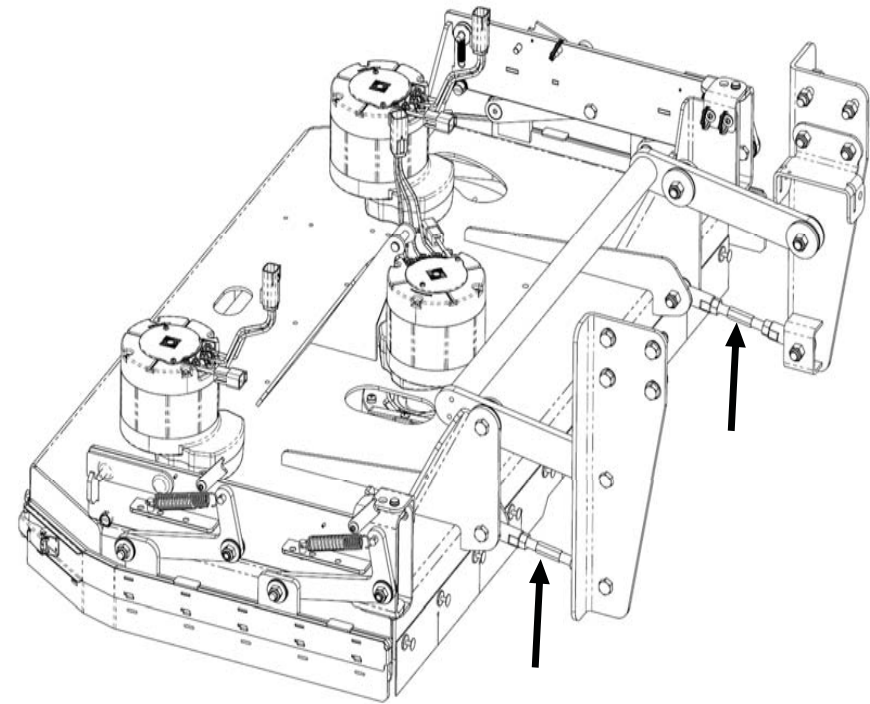

Fig. 1: Leveling Rods

SWEEP COMPONENTS

Broom Flap Inspection

NOTE: Perform this inspection when the machine is parked on a level surface.

1. Turn the machine off and lock the parking brake.
2. Inspect broom flaps for wear and damage. Flap clearance should be 1/8" (3.18 mm) above the floor.
3. Worn and damaged flaps should be replaced immediately to maintain proper dust control.

Broom Flap Replacement and Adjustment

The flaps are attached to the broom chamber by a retainer bar, hex bolts and nuts. To remove the flaps, remove the nuts, bolts and retainer bar. To adjust the flaps, loosen the nuts and bolts, slide the flap up or down as needed. Retighten the nuts and bolts.

Main Broom Replacement

NOTE: Broom should be replaced if bristles are worn to the broom indicator.

1. Turn the engine off and lock the parking brake.
2. Push the broom switch to the off position.
3. Open the right broom chamber door (the door on the driver's side).
4. Remove the knob on the main broom idler mount.
5. Pull the main broom idler mount straight out to remove.



6. Grasp the main broom by the plastic drive hub, pull the main broom straight out and clear of the broom chamber.
7. Depending on broom condition, you can either rotate the old broom end-to-end and re-install it or you can install a new broom. Slide the main broom into the broom chamber and align the broom with the metal drive hub located at the far side of the broom chamber. If a worn broom is being replaced, install the new broom by first adjusting the broom arms up to better match the position of the drive hub with the hub on the new broom.
8. Once the broom is started into the drive hubs, rotate the broom counterclockwise while pushing lightly against the broom.
9. Once the broom is fully engaged, replace the idler hub.
10. Install the retaining knob and tighten into position.
11. Perform a main broom adjustment test and adjust as needed.

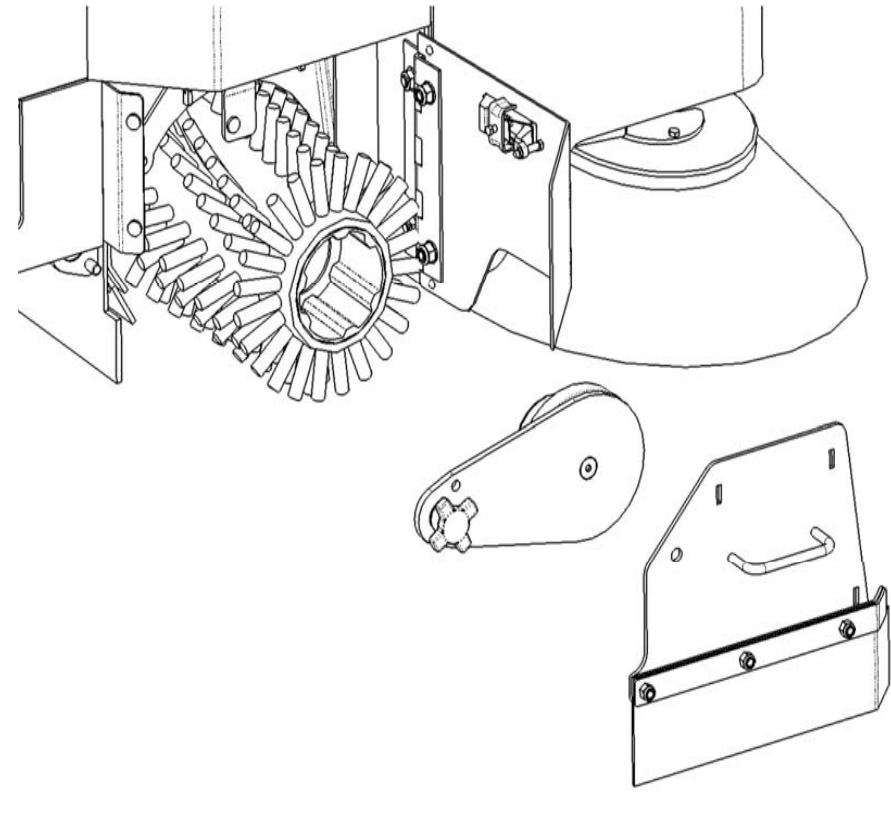

Main Broom Pattern Check

NOTE: Perform this assessment on a flat, smooth test surface. You may spread baby powder or chalk on the test surface area to make the broom pattern more visible.

1. Drive the machine onto the test surface.
2. Set the parking brake and put the brush switch in the on position.
3. Depress the speed control pedal just enough to turn on the brush motor.
4. Allow about 45 seconds for the broom to operate, then deactivate the broom motor and raise the broom.

NOTE: Test time will vary according to the test surface used.

5. Drive the machine clear of the test site.
6. Examine the pattern made by the broom on the test area.

NOTE: A rectangular shape the length of the main broom indicates the main broom is properly adjusted. If pattern is tapered from end to end instead of rectangular adjust as shown on the next page.

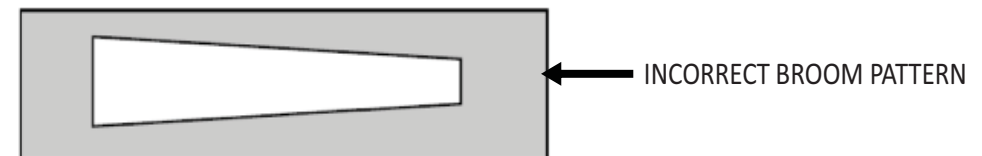
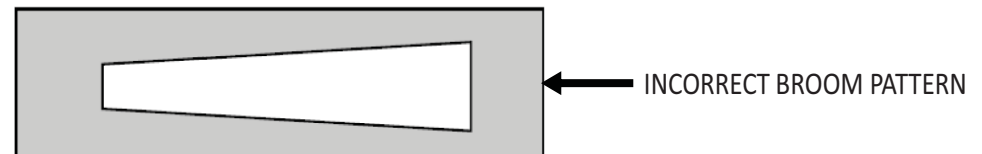
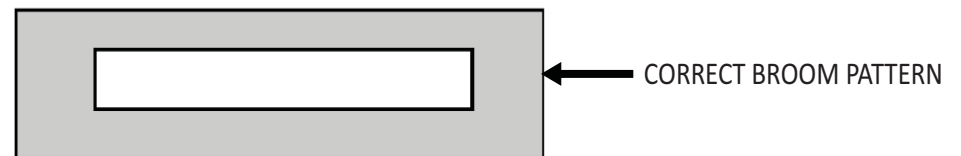

Main Broom Taper Adjustment

NOTE: It is not usually necessary to perform this adjustment. However, if the main broom assessment shows a pattern that is tapered in length (one end is wider than the other), perform the procedure which follows.

1. Locate adjustment bolts on right side of main broom. See Fig. 1.
2. Loosen the jam nuts.
3. Move the adjustment bolts up or down as needed to achieve proper broom pattern.
4. After adjustment, re-tighten the bolt.
5. Repeat the main broom adjustment test to see that the broom is properly adjusted.

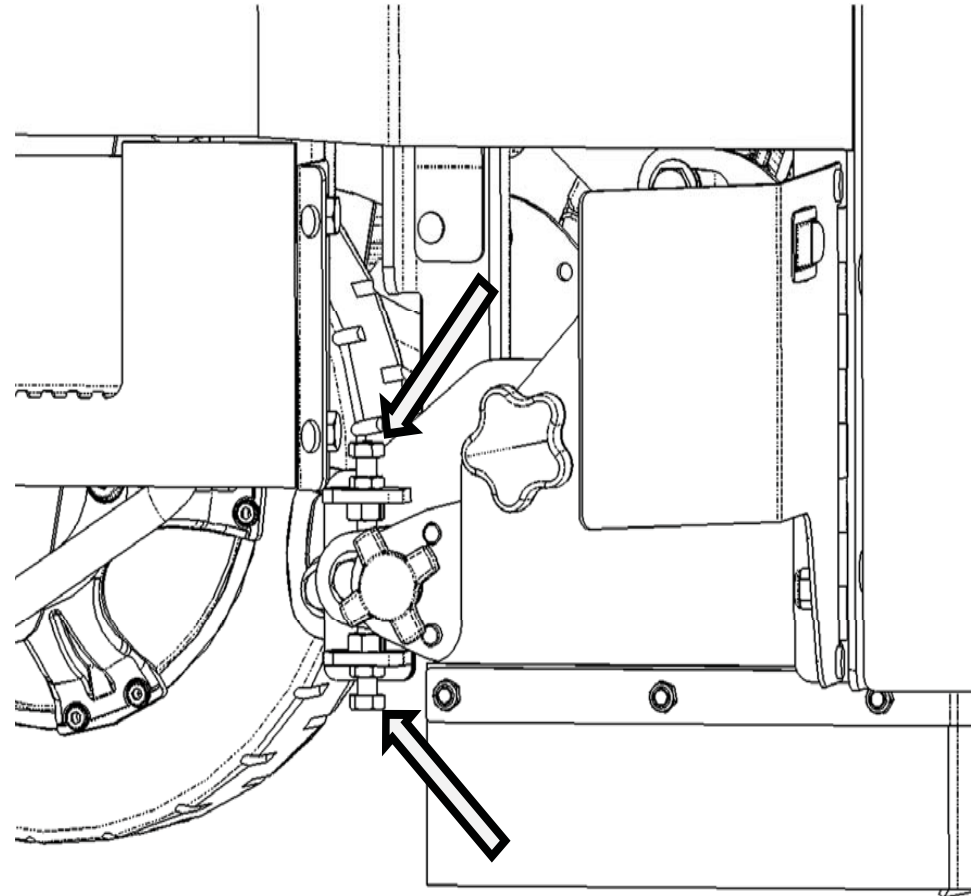

SIDE SCRUB BRUSH (OPTION)

Replacing the Side Scrub Brush

1. Raise the side scrub brush.
2. Turn off the machine.
3. Set the parking brake.

For Safety: Before leaving machine, turn off the machine, set the parking brake, and remove the key.

4. Rotate the brush until the brush release tabs are accessible through the opening in the brush guard.
5. Press the release tabs together. The brush will fall off of the brush drive hub.
6. Lift a new brush onto the brush drive hub to lock it into place.
7. Check to be sure that the brush is securely retained.

Note: Check the side brush daily for wear. The side scrub brush should be replaced when it is no longer cleaning effectively, or the bristle length has worn to 2.5 inches (5,08 cm) from the block.

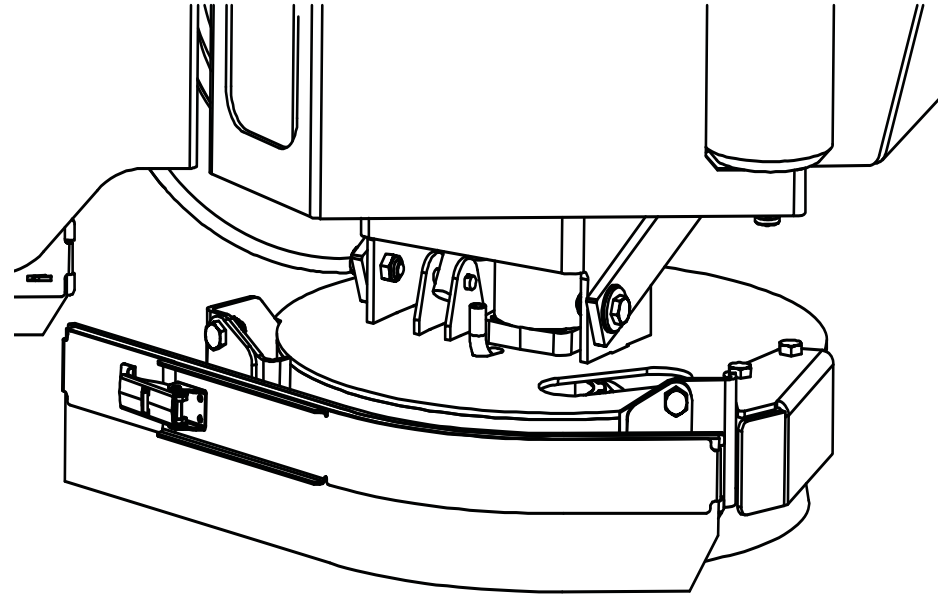

Fig. 1: Replacing the Side Scrub Brush

SQUEEGEES

The right and left side squeegees control water during turns and channel water toward the center of the machine and into the path of the rear squeegee.

The rear squeegee channels water to the center of the squeegee where it is removed by the vacuum fan.

The optional side scrub brush squeegee channels water to the inside of the right side squeegee.

Check the squeegee blades daily for wear or damage. Replace or rotate the squeegee blades if the edges are torn or worn half-way through the thickness of the blade.

The rear squeegee blades must be adjusted to be level and for correct deflection.

Lowering Squeegee for Adjustment

To lower the squeegee for adjustment. Follow the steps below:

1. With machine running; Turn "on" green one touch and Squeegee switch. Squeegee will lower to the ground.
2. Turn off the key switch.
3. Squeegee will remain on the ground. Repeat steps 1-3, if necessary.

4. The squeegee can be adjusted.

Checking the Rear Squeegee Blade Flare

Squeegee flare is the amount of curl in the squeegee blade as it drags on the floor while the machine is moving forward. Correct squeegee blade flare is necessary for optimum water pick up. The correct flare adjustment is achieved when the squeegee wipes the floor dry with the least amount of deflection. It is important that this check be performed on an even, level surface.

1. Lower the squeegee.
2. Drive the machine forward approximately 2 ft (0,6 m).
3. Set the parking brake.
4. Examine the curl in the squeegee rubber to see that the flare is correct and that it is uniform around the entire back edge of the squeegee blade:

If the flare is uniform but the amount of flare is incorrect proceed to the section on **Adjusting the Rear Squeegee Blade Flare**.

If the flare is not uniform proceed to the section on **Leveling the Rear Squeegee**.

Adjusting the Rear Squeegee Blade Flare

Be sure that the squeegee assembly is adjusted to level before performing the flare adjustment. It is important that this adjustment be performed on an even, level surface.

Note: Raising the squeegee casters increases the squeegee flare, lowering the casters reduces the squeegee flare.

1. Lower the squeegee.
2. Turn off the key switch Set the parking brake.
3. Lift the squeegee assembly up by hand and allow it to rest back down on the floor. The squeegee blade should be standing straight up on the floor with no flair.
4. Loosen the locking knobs on the squeegee casters.
5. Adjust the casters until they clear the floor by .25 in (0,63 cm). Use a .25 in (0,63 cm) thick spacer for this procedure.
6. Check the squeegee flare (See **Checking the Rear Squeegee Blade Flare**).
7. Test the squeegee for water pick up.
8. Make fine adjustments to the caster height for optimum water pick up on the floor surface to be cleaned.

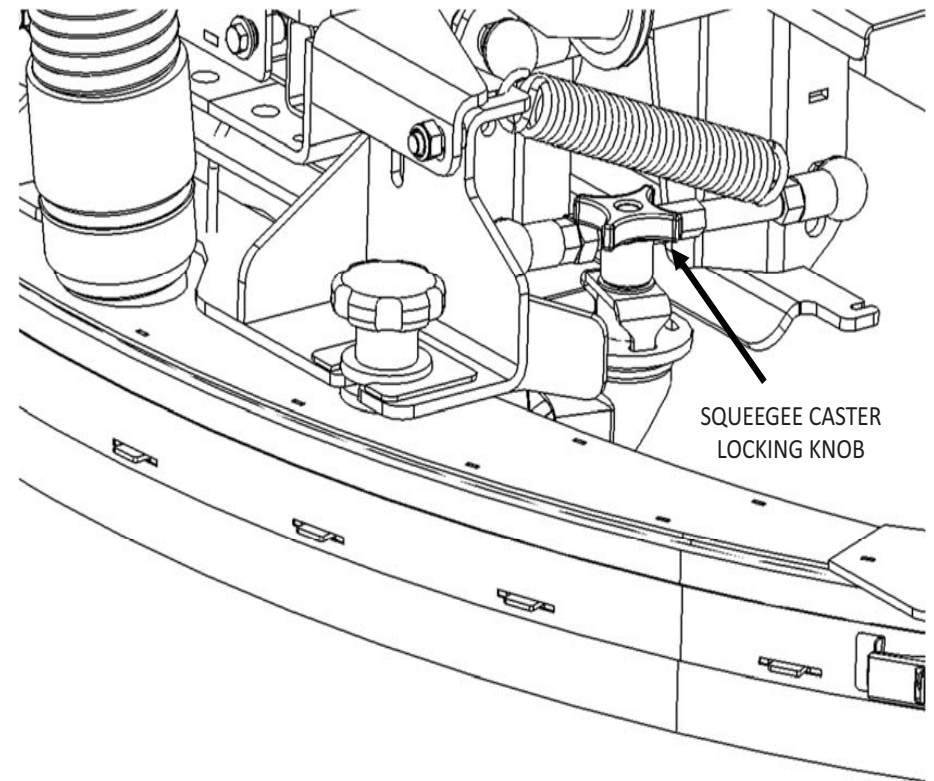

Fig. 1: Adjusting the Rear Squeegee Blade Flair

Leveling the Rear Squeegee

Leveling the squeegee assembly provides a uniform flare of the squeegee blade. It is important that this adjustment be performed on an even, level surface.

1. Lower the squeegee.
2. Drive the machine forward approximately 2 ft (0,6 m).
3. Set the parking brake.
4. Examine the curl in the squeegee rubber around the entire back edge of the squeegee blade.

If the flare is not even across the rear squeegee blade proceed with the following:

5. Locate the pitch rod adjustment nuts on the lift plate.

Note: Raising the rear bumper and then lowering the squeegee will provide greater access to the adjusting nuts.

6. To lower the front of the squeegee turn the two adjustment nuts on each adjustment rod rearward (away from the front of the machine).

To lower the rear of the squeegee turn the two adjustment nuts on each adjustment rod forward (toward the front of the machine).

7. Lock the adjustment nuts.
8. If necessary proceed to **Adjusting the Rear Squeegee Blade Flare.**
9. Test the squeegee for water pick up.
10. Re-adjust to level the squeegee if necessary.

Turning or Replacing the Rear Squeegee Blades

Check the squeegee blades daily for wear or damage.

After the squeegee edge wears half-way through the thickness of the squeegee blade the squeegee blade can be turned over so that a new edge will be against the cleaning surface.

After the second edge wears the squeegee blade can be turned end-to-end to use the third edge, and finally turned over once again to use the fourth edge.

Replace any damaged squeegee blade.

Note: The rear squeegee blade can be accessed with the rear bumper raised or closed. With the rear bumper raised the outer squeegee can be turned or replaced without removing the squeegee tool from the machine. Servicing the inner squeegee is best done with the squeegee tool removed from the machine.

WARNING

When Servicing or working around or under raised hopper or squeegee lift:

Install the hopper and squeegee lift pins.

1. Ensure that the rear squeegee is raised up off of the floor.
2. Shut off the machine and set the parking brake.

For Safety: Before leaving machine, turn off the machine, set the parking brake, and remove the key.

3. Raise the rear bumper.
4. Loosen the two squeegee retaining knobs. (See Fig. 1)
5. Pull the lower end of the squeegee hose from the squeegee tool. (See Fig. 1)

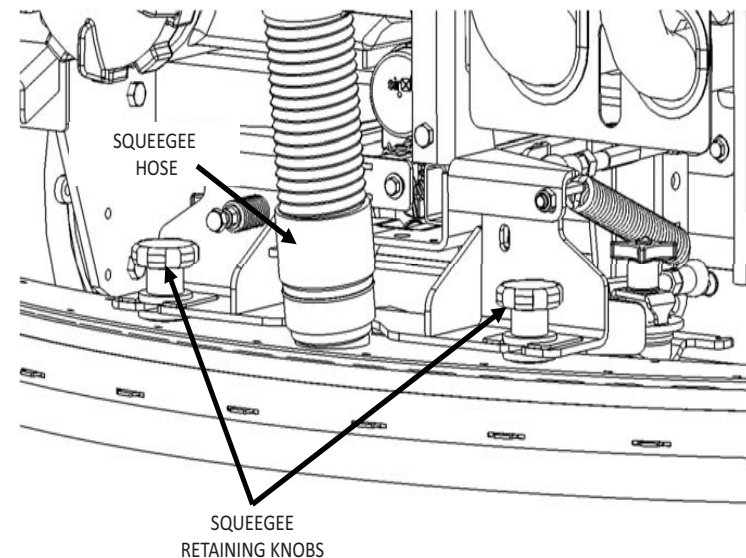

Fig. 1: Turning/Replacing the Rear Squeegee Blades

6. Lift the squeegee tool off of the squeegee frame
7. Remove the squeegee retainer bands.
8. Replace or turn the squeegee blades by placing the blade onto the pins of the squeegee frame.
9. Replace the squeegee retainer straps and close the latch.

Note: When reinstalling the squeegee tool insure that the washers below the squeegee retaining knobs are positioned between the knobs and the squeegee tool mount.

10. Lower the rear bumper.
11. Adjust the rear squeegee as shown in Adjusting the Rear Squeegee Blade Flare.

SIDE SQUEEGEES

The right and left side squeegees control water during turns and channel water toward the center of the machine and into the path of the rear squeegee.

Replace the side squeegees if they become worn, damaged, or lose their shape.

Replacing Side Squeegee Blades

1. Raise the scrub deck.
2. Turn the key off and set the parking brake.

For Safety: Before leaving machine, turn off the machine, set the parking brake, and remove the key.

3. Open the side squeegee door.
4. Open the latch on the side squeegee retaining strap and remove the retaining strap. (See Fig. 1)

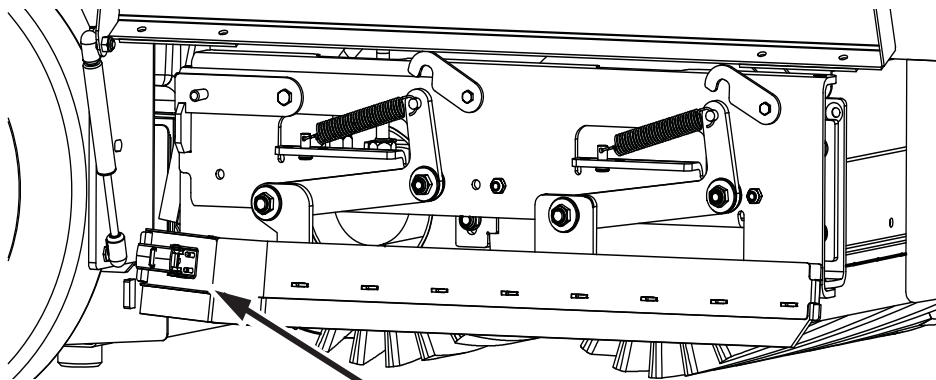

Fig. 1: Side Latch

5. Replace the side squeegee blade by placing the blade onto the pins of the side squeegee frame.

Note: Position the beveled edge of the side squeegee blade down and toward the front the machine.

6. Replace the side squeegee retainer strap by first hooking the forward end around the notch at the front edge of the side squeegee frame. (See Fig. 2)
7. Close the latch on the side squeegee retaining strap and close the side squeegee door.
8. Repeat the procedure for the side squeegee on the other side of the machine.

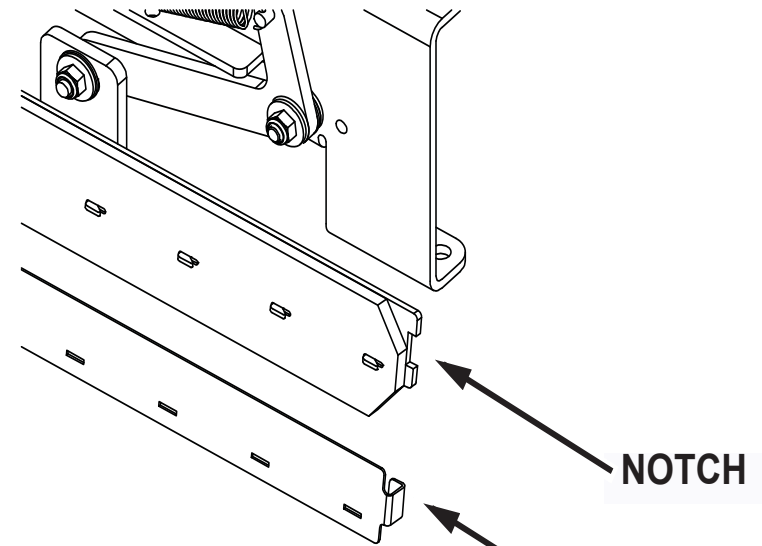

Fig. 2: Hooking the Strap

SIDE SCRUB BRUSH SQUEEGEE (OPTION)

The side scrub brush squeegee channels water to the inside of the right side squeegee and into the path of the rear squeegee.

Replace the side scrub brush squeegee if it becomes worn, damaged, or loses its shape.

Replacing Side Scrub Brush Squeegee Blade

1. Remove squeegee guard by unlatching from side brush.
2. Open the latch on the squeegee retaining strap and remove the retaining strap. (See Fig. 3)
3. Replace the squeegee blade by placing the appropriate set of holes on the squeegee blade onto the pins of the side squeegee frame.
When the side scrub brush is new: Use the upper set of holes.
When the brush is moderately worn: Use the center set of holes.
When the brush is very worn: Use the lower set of holes.

Note: Position the beveled edge of the squeegee blade down and toward the front the machine.

4. Replace the squeegee retainer strap by first hooking the separate straps around the notches at the front and rear edge of the squeegee frame.
5. Close the latch on the side squeegee retaining strap.

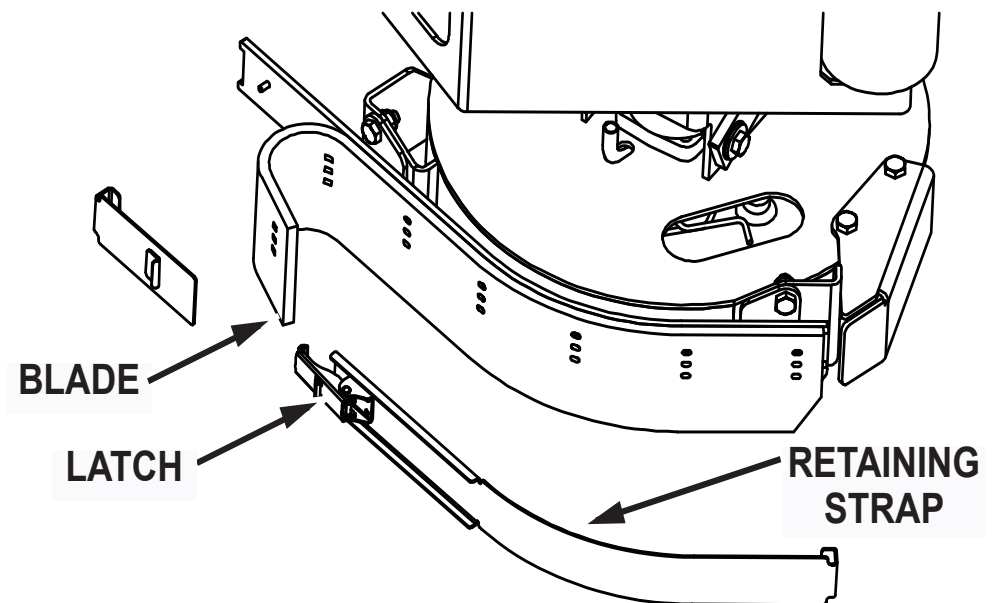

Fig. 3: Retaining Strap & Blade

SKIRTS AND SEALS

Scrub Deck Front Skirt

The Front Skirt is mounted to the front of the scrub deck.
(See Fig. 1)

Check this skirt for wear or damage every 100 hours of operation.

Hopper Dump Door Seals

Check the dump door seals every 100 hours and replace if worn or damaged.

Cover Seals

The Cover Seals are attached to each of the solution and recovery tank covers. (See Fig. 4)

Check these seals for wear or damage every 100 hours of operation.

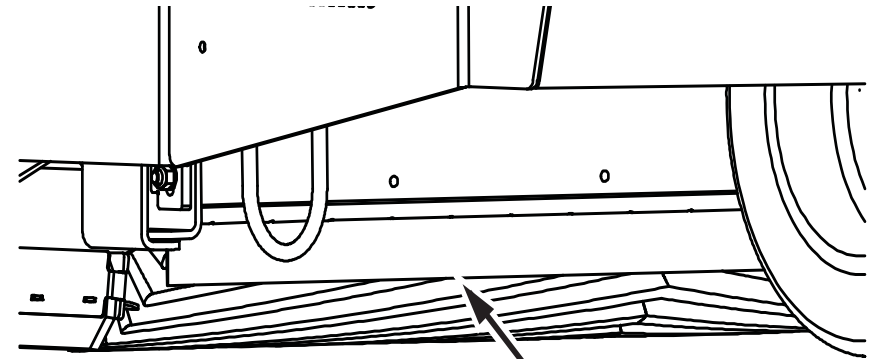

Fig. 1: Scrub Deck Front Skirt

**CHECK SKIRT
FOR WEAR**

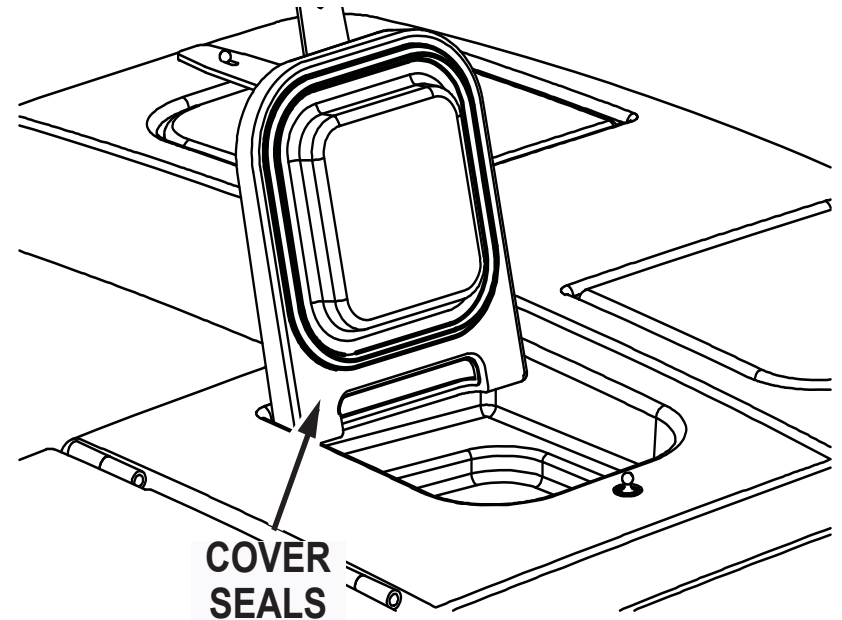

Fig. 4: Cover Seals

**COVER
SEALS**

BRAKES

Service Brakes

The service brakes are operated by a foot pedal and connecting cables. (See Fig. 1)

Check the service brake adjustment every 200 hours of operation.

Parking Brake

The parking brake is operated by a locking foot pedal that activates the service brakes. (See Fig. 1)

Check the service brake adjustment every 200 hours of operation.

Adjusting the Brake System

Both the service and parking brake are adjusted during the following cable length adjustment.

The brake cable adjustment is located under the operator behind the scrub deck.

1. Loosen the locking nut on the adjustment hex bar.
2. Adjust the length of the cable by turning the adjustment hex bar.

Note: The cable should be adjusted so that there is little play in the brake pedal but not so tight to cause the brakes to drag when the brake pedal is released.

3. Test the brakes and re-adjust if necessary.
4. Tighten the locking nut.

DRIVE WHEEL MOTOR

The drive wheel motor oil drain plug is located under the motor. The oil should be replaced every 800 hours.

REAR TIRES

The rear tires are solid press-on tires.

Check the tires for damage every 100 hours of operation.

Note: The procedures that follows applies to SOLID TIRES ONLY.

1. Remove the tire by removing the center axle nut.
2. Pull the rear tire straight off of the axle.
3. Remove the inner and outer bearings. Note which is the inner bearing and which is the outer bearing so that they are reinstalled in the same location.
4. Press the tire from the rim.
5. Press the new tire onto the rim.
6. Clean the inner and outer bearing races and bores.
7. Clean the bearings. Inspect the bearings and races for wear, replace if necessary.

8. Grease the bearings with LUBRIPLATE EMB Grease or equivalent.
9. Install the bearings in the wheel. Ensure that the bearing seals are seated correctly and be careful not to get any grease on the brake surface or brake pads.
10. Reinstall the tire on the machine by holding the wheel parallel to the side of the vehicle and firmly push it onto the axle.
11. Torque the wheel nut to 60 lb·ft (81 N·m).
12. Align the hole in the axle with the closest slot on the nut and install the cotter pin.
13. Install the hub cap.

SEAT MOUNT ADJUSTMENT:

The seat mount is opened by pulling on the latch handle protruding out from the front of the seat mount then lifting the back of the seat mount.

The seat mount will lock in the raised position. To unlock the seat mount lift the seat mount lock arm and lower the seat mount.

The seat mount can be removed by first disconnecting the lock arm from the frame pin and then rotating the two seat mount hinge retaining bars toward the front of the machine. The seat mount can then be lifted off.

To reinstall the seat mount set the seat mount into the hinge receivers, reconnect the lock arm, and lower the seat mount. The seat mount retaining bars will latch automatically.

SOLUTION DELIVERY BAR & FILTER SYSTEM

Solution Delivery Bar

Located under the machine and in front of the main brush housing, visually inspect the Solution Delivery Bar for plugged discharge holes. Clean the discharge holes with a small wire brush or pipe cleaner as needed. Keep the holes free and clear of debris. (See Fig. 1)

Check Solution Delivery Bar every 200 hours of operation.

Solution Filter

Turn the ke off, and set the parking brake. The solution filter is located on the left side of the machine in front of the scrub deck. Visually inspect the filter element for debris. Clean filter element with fresh water and a small brush. Keep the filter element free of debris. (See Fig. 2)

1. Shut off the valve.
2. Unscrew filter cap counter clockwise to remove the filter cap and filter element from base.
3. Clean filter element with fresh water and a small brush to remove debris.
4. Reassemble filter and screw filter cap back on to base.

Check the water Solution Filter every 50 hours of operation.

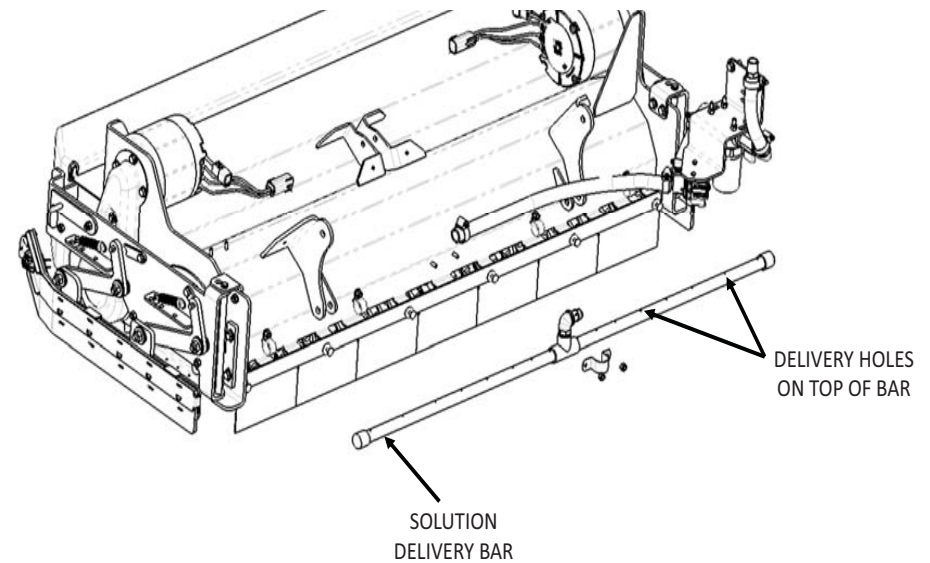

Fig. 1: Solution Delivery Bar shown with holes

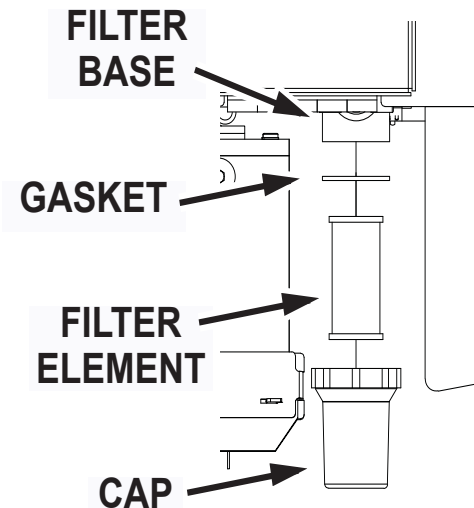

Fig. 2: Water Solution Filter with Exploded view

TROUBLESHOOTING

This section provides information to assist in identifying maintenance trouble and provides possible causes and actions to correct the problem. Many of the solutions require servicing your machine. Service must be preformed by an approved authorized repair station.

TROUBLESHOOTING CHART

PROBLEM	POSSIBLE CAUSE(S)	SOLUTION(S)
Machine will not start or runs roughly after start.	Battery dead	Recharge or replace battery.
	Circuit Breaker 2 tripped	Reset the circuit breaker
	Keyswitch bad	Replace it
Nautilus E® machine moves slowly or does not move.	Parking brake is on.	Release brake.
	E-stop button depressed	Release it
Brushes do not turn or turn very slowly.	Brush switch not on.	Press to on position.
	Foot pedal not depressed.	Press to forward position.

TROUBLESHOOTING CHART

PROBLEM	POSSIBLE CAUSE(S)	SOLUTION(S)
Poor water pick-up	Worn or torn squeegee blades	Rotate or replace blades
	Squeegee out of adjustment	Adjust so blades touch floor evenly across entire width
	Recovery tank is full.	Empty the tank; if foaming badly, change detergent
	Recovery tank lid gasket leak	Replace gasket lid cover properly
	Debris caught in squeegee	Clean squeegee
	Vacuum hose clogged	Remove debris and flush hose
	Using too much solution	Adjust solution control valves
	Vacuum hose to squeegee or recovery tank disconnected to squeegee or damaged	Reconnect or replace squeegee hose
Inadequate solution flow or no solution being delivered to the floor	Solution tank is empty.	Fill tank
	Solution solenoid valve	Clean or replace valve
	Recovery tank full	Clear lines
	Solution lines, valves, filter or spray jets clogged	Flush lines, and clean solution filter and spray jets

TROUBLESHOOTING CHART

PROBLEM	POSSIBLE CAUSE(S)	SOLUTION(S)
Scrubber unit not cleaning the floor.	Brushes worn.	Rotate or reeplace brushes
	Need different type of brush or detergent.	Use manufacturer's recommended brushes / detergent
	Debris caught in brush drive mechanism.	Clear obstruction
	Brushes out of adjustment.	Adjust
	Moving machine too fast	Slow down
Scrub head will not lower	Fuse blown	Replace fuse
	Loose scrub head switch wires	Connect wires
	Loose connection of plug at actuator	Connect
	Defective actuator	Replace actuator
	Defective scrub head switch	Replace switch
	Circuit Breaker 3, 10 amp breaker triped	Reset it
Squeegee will not lower.	Loose or defective squeegee switch (on console).	Reconnect wiring or replace switch.
	Loose wire(s) at foot pedal.	Connect.
	Foot pedal switches need adjustment.	Re-adjust cams.

TROUBLESHOOTING CHART

PROBLEM	POSSIBLE CAUSE(S)	SOLUTION(S)
Squeegee will not raise in reverse or by console switch.	Foot pedal switches need adjustment.	Re-adjust cams.
	Defective solenoid valve.	Replace solenoid valve or coil.
	No power at valve.	Check fuse.
Scrubber leaving debris.	Hopper full.	Dump hopper.
	Brushes out of adjustment.	Adjust.
	Brushes bristles worn.	Check for wear and adjustment.
	Poor performance of brush drive mechanism.	Check for jam in broom chamber.
	Hopper flaps damaged or missing.	Replace.

TROUBLESHOOTING DRIVE CONTROLLER (718199)

PROBLEM	POSSIBLE CAUSE(S)	SOLUTION(S)
Unit will not drive	Over heated-temp sensor open	let cool down
Neither LED illuminated, but controller is operating normally	Controller is not powered on	F-1 (300amp) fuse blown, R-1 relay bad, or not switching, Circuit breaker 2 tripped, E stop pushed in.
	Vehicle has dead battery, or severely damaged battery	Call service
Yellow LED flashing	Check Drive motor connections	Call service

TROUBLESHOOTING DRIVE CONTROLLER (718199)

PROBLEM	POSSIBLE CAUSE(S)	SOLUTION(S)
Yellow and red LEDs both on solid	Controller is in flash program mode	Call service
Red LED on solid	Internal hardware fault detected by the supervisor or primary microprocessor	Call service
	Missing or corrupt software (Interrupting a software download may cause corruption of the software)	Cycle KSI to clear. Reload or replace controller if necessary. Call service.
Red LED and yellow LED flashing alternately	Controller has detected a fault. (2 digit code flashed by yellow LED identifies the specific fault. One or two flashes by red LED indicate whether first or second code digit will follow.	Call service

TROUBLESHOOTING STEERING CONTROLLER (718203)

PROBLEM	POSSIBLE CAUSE(S)	SOLUTION(S)
Unit will not steer	Circuit Breaker 9 (30 amp) tripper	Reset the breaker
	Check J1-15 for 36 volts supply voltage Possible broke/pinched wire from key switch	Call service

TROUBLESHOOTING STEERING CONTROLLER (718203)

PROBLEM	POSSIBLE CAUSE(S)	SOLUTION(S)
LED blinks 8 times	Controller detects a failure on the external power fuse/power connections or internal relay damaged	Check Breaker 9, and J1-15 relays, if okay, then call service.
LED blinks 10 times	Battery voltage upper than 45V,.	Check the battery or power connections status. Call service
LED blinks 11 times	Motors ammeter protection	Check motor connections. If good, call service.
LED blinks 12 times	Motor's thermal switch ON	Let cool, and try again. If still not steering, call service.
LED blinks 13 times	Key switch was opened.	Check the key switch connections. If good, call service.

TROUBLESHOOTING BRUSH CONTROLLER (714623)

PROBLEM	POSSIBLE CAUSE(S)	SOLUTION(S)
Brushes not turning	Check circuit breakers 6 and 7	Reset breaker.
Controller Code A5	Thermal protection	Wiat few minutes and check the motor current.

TROUBLESHOOTING BRUSH CONTROLLER (714623)

PROBLEM	POSSIBLE CAUSE(S)	SOLUTION(S)
Controller Code A9	Under-voltage	Check batteries charge.
Controller Code A11	Overload Protection	Check the motor working current, and parameters “rated current” and “over-load time”
Controller Code A12	Disable switch on	Check the input switch. This alarm will reset by power-off.
Any other Controller Codes		Call Service.



PowerBoss[®]

The Power of Clean

**PowerBoss[®] is a Full Line Manufacturer of Sweepers and Scrubbers,
for Industrial Facilities.**

PowerBoss[®], Minuteman International, Inc., 14N845 U.S. Route 20 Pingree Grove, Illinois 60140
Phone: 800-323-9420 www.PowerBoss.com e-mail: tech@powerboss.com
A Member of the Hako Group

Nautilus E Rider Scrubber / Sweeper #988768UM-D Rev. B 11/20

© 2014-2015 Minuteman International, Inc.